Disconnectors and Main Switches acc. to IEC 60947-3 see Catalog 500

Contents	Page
Construction Data	4
Dimensions and Nominal Ratings	5
How to order	6, 7
Switch Function and Configuration	
C, CA and CAD Switches 10 A-315 A	
ON/OFF Switches	9
Double-throw Switches	10-12
General Application Switches	12
Coding Switches	13
Multi-step Switches	14-16
Voltmeter Switches	17-18
Ammeter Switches	19-21
Volt-ammeter Switches	21
Control Switches	21, 22
Motor Switches	23-25
L Switches 350 A-2400 A	
ON/OFF Switches	26, 27
Double-throw Switches	28, 29
Multi-step Switches	30-32
Types of Mounting	
Panel Mounting	33-37
Base Mounting	38
Wall Mounting	39
Face Plates	40, 41
Handles	42
International Standards and Approvals	43
Technical Data	44-48
Dimensions	
Panel Mounting	49-53
Base Mounting	53, 54
Wall Mounting	55
Overall Switch Lengths	55, 56
Blue Line Switchgear: Summary	58

Construction Data

The load switches of the C, CA and CAD-series offer a solution for most cam switch applications. Different contact designs, contact materials and terminals allow for their use as control switches, instrumentation switches and motor control switches, as well as in electronic circuitry and in aggressive environments according to IEC 60947-3 and VDE 0660 part 107.

The stage is the basis for all switches and can be supplied with a maximum of 2 contacts. The terminals are accessible from the side. CA and CAD switches are supplied with open terminals to facilitate wiring and are protected against accidental finger contact according to EN 50274, VDE 0660 part 514 and DGUV V3. Switches up to type CA25B are supplied with captive screws with clamping plates. The switch types CA40-CA63 are supplied with box terminals. Captive plus-minus terminal screws and integrated screwdriver guides facilitate wiring.

If a positive manual operation or a higher DC rating is required, many of these switches can be fitted with a snap action latching mechanism - suffix „S“ - to the switch type.

The cam-operated switches of the L-series are continuous current rated for off-load switching. They may be used to switch resistive or low inductive loads.

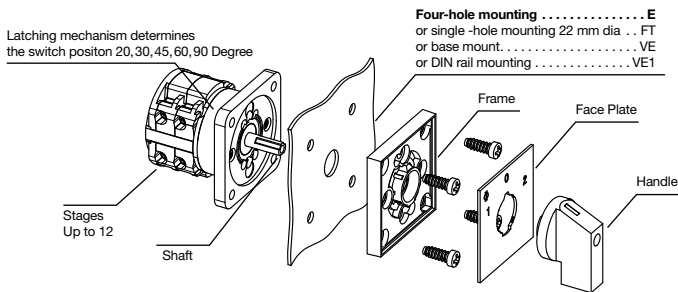

Special Contact Systems

CA4/CA4-1

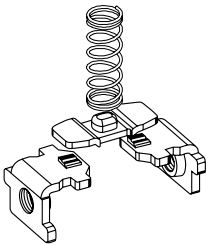

High contact reliability by multiple cross-point contacts, electronic compatible.

CAD4-1/CAD11/CAD12

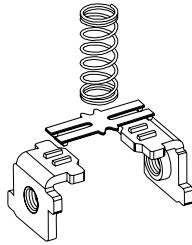

High contact reliability by H-bridge design with "cross-wire" contacts. The contact system with gold-plated contacts (CAD12 with silver contact) allows for low voltages, electronic compatible.

Type	Size	Possible Switching Angles	Max. No. of Stages
CA4, CA4-1, CAD4-1	S00	30°, 45°, 60°, 90°	9
CA10-CA25	S0	30°, 45°, 60°, 90°	12
CA10S-CA25S	S0	60°, 90°	on request
CAD11, CAD12	S0	30°, 45°, 60°, 90°	12
CA10B-CA25B	S1	30°, 45°, 60°, 90°	12
C26, C32, C42	S1	20°, 30°, 45°, 60°, 90°	12
C26S, C32S, C42S	S1	60°	on request
CA40, CA50, CA63	S1	30°, 45°, 60°, 90°	12
C43, C80, C125, C200-4	S2	20°, 30°, 45°, 60°, 90°	12
C315	S3	30°, 45°, 60°, 90°	12
L350, L351, L630, L631	S2	30°, 45°, 60°, 90°	12
L1000			
L400, L600, L800, L1200, L1600, L2000	S3	30°, 45°, 60°, 90°	12

CA and CAD Switches (CA4-CA25B)



CA Switches (CA40-CA63)



C Switches



L Switches



Above illustrates the standard terminal positions.

Nominal Ratings

Switch Size	Type	According to IEC 60947-3/VDE 0660 part 107			
		Insulation Voltage ¹ U_i V	Thermal Current I_u/I_{th} A	Motor Rating 3 x 380 V-440 V AC-23 AC-3 kW kW	
S00 	CA4	440	10	3	2,2
	CA4-1	440	10	3	2,2
	CAD4-1	440	5	-	-
S0 	CA10	690	20	7,5	5,5
	CA11	690	20	7,5	5,5
	CA20	690	25	11	7,5
	CA25	690	32	15	11
	CAD11	600	6	-	-
	CAD12	600	6	-	-
S1 	CA10B	690	20	7,5	5,5
	CA11B	690	20	7,5	5,5
	CA20B	690	25	11	7,5
	CA25B	690	32	15	11
	C26	690	32	15	11
	C32	690	50	22	15
	C42	690	63	30	18,5
	CA40	690	40	18,5	15
	CA50	690	50	22	18,5
	CA63	690	63	30	18,5
S2 	C43	690	63	30	18,5
	C80	690	115	45	30
	C125	690	150	75	37
	C200-4	690	200	75	37
	L350	690	350	90	37
	L351	690	350	90	37
	L630	690	630 ²	90	37
	L631	690	630 ²	90	37
	L1000	690	1000 ²	90	37
S3 	C315	690	315	132	55
	C316³	1000	315	132	55
	L400	690	500	132	55
	L600	690	800 ²	132	55
	L800	690	1100 ²	132	55
	L1200	690	1450 ²	132	55
	L1600	690	1900 ²	132	55
	L2000	690	2400 ²	132	55

For further technical details, refer to pages 44-47.
To furnish with gold contacts and quick connects see page 6.

¹Valid for lines with grounded common neutral termination, overvoltage category III, pollution degree 3. Values for other supply systems on request. ²Ambient temperature 35 °C max. ³Additional switch functions on request.

How to order

Disconnectors and Main Switches according to IEC 60947-3 see Catalog 500

Three types of data (shown below) are required for ordering Blue Line cam-operated switches. Code numbers for ordering are shown in this catalog.

1. Type of Switch

The type of switch required may be easily selected by referring to the table on page 5 which shows the thermal current, power rating and dimensions of each switch. For further technical details, refer to pages 44-47. Variations of contacts and terminals are shown below.

2. Switch Function

The code numbers for standard switches shown on pages 8-32 indicate the switch function, face plate, handle and any optional extras.

Additional coding to modify type and color of handle and face plate is explained below.

3. Type of Mounting

Types of mounting are shown on pages 33-39. Catalog **101** describes enclosures and optional extras.

Specify the mounting code to indicate required mounting.

CA10

A202

VE

Type of Switch

Extending the switch type coding the following combinations will define:

Amendment	Definition	For switch types
-1	with gold contacts ¹	CA4-1, CA4N-1, CA10-1, CA11-1, CA10B-1, CA11B-1, CAD4-1
-4	with quick connects	CA4-4
B ²	S0 switches with latching mechanism size S1	CA10B, CA11B, CA25B, CAD11B, CAD12B
C ²	S1 switches with latching mechanism size S2	CA40C, CA50C, CA63C
L	with lockout-relay w/o manual release for std. sw.	CA10L, CA25L, C26L
M	with lockout-relay with manual release for std. sw.	CA10M, CA25M, C26M, C42M
X	with power failure release	CA10X, CA20X, CA25X, C26X, C32X, C42X
Y	with power failure release and trip-free release	CA10Y, CA20Y, CA25Y
S ²	with snap action	CA10S, CA20S, CA25S with 60° or 90° switching C26S, C32S, C42S, CA40S, CA50S, CA63S with 60° switching
R	with spring return latching mechanism	CA10R, CA25R, CAD11R, CAD12R

Example: Coding for switch type **CA10** with gold contacts is **CA10-1**.

Handles, Face Plates and Optional Extras

The handles for standard switches shown on pages 8-32 are suitable for mounting units with four hole mounting. Alternative types of handles available are illustrated on page 42, and mounting units on pages 31-37.

When a handle, face plate or optional extra is required but not covered by the dash number, the code number for the selected component should be entered separately. A comprehensive range of available standard face plates is illustrated on pages 40 and 41. Non-standard or special face plate engravings are available at extra cost.

The large number of optional extras and enclosures is covered in Catalog **101**.

Switch Size

Blue Line switches are available in sizes S00, S0, S1, S2 and S3. These size codes indicate the dimensions of the mounting, the face plate and the handle, as well as the size of optional devices and enclosures.

Page 5 lists these sizes and the various switch types they include.

¹Technical data on request. ²Additional length for switches with B, C, S, amendments refer page 54.

Notes:

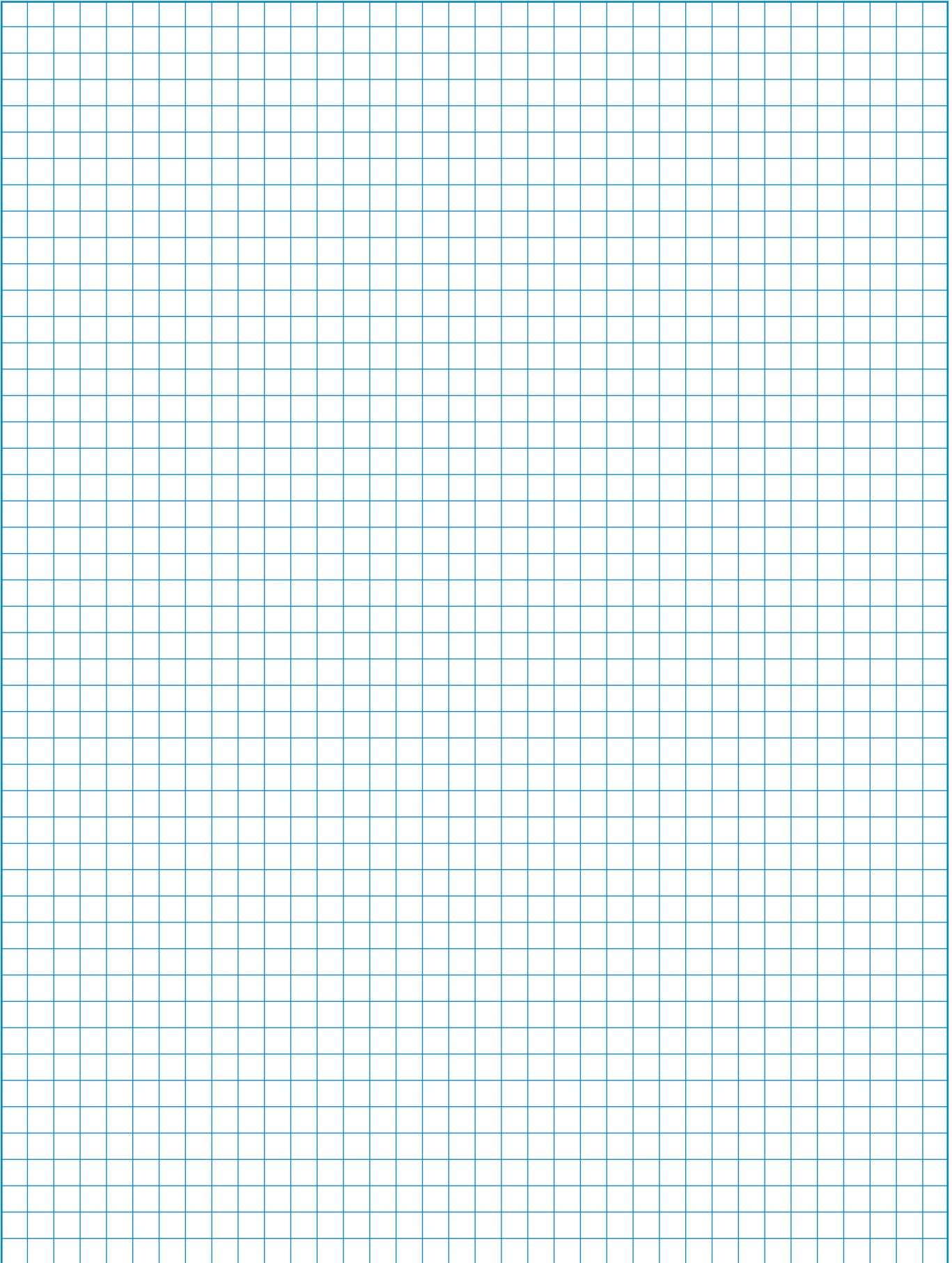

[< back to table of contents >](#)















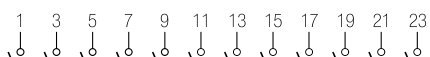















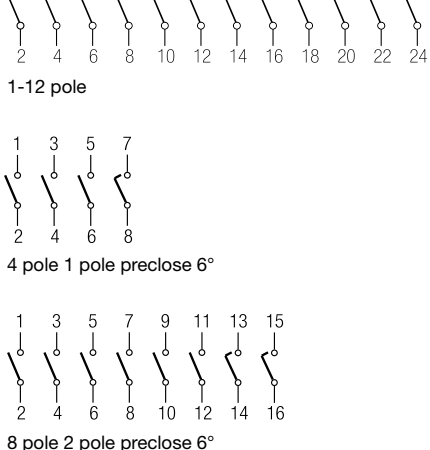

























Switch Function and Configuration

C, CA, CAD Switches

Function	Escutch. Plate	Type/Handle				Code	Stages	Connection Diagram
		CA4 CA4-1 CAD4-1	CAD.. CA10- CA25	CA10B- CA25B	CA40 C26- C315			















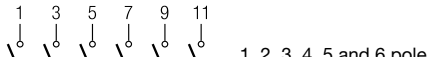







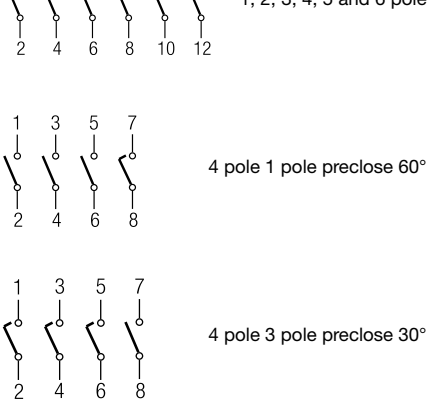















ON/OFF Switches with 60° Switching

[Dimensions p.56](#)





































1 pole	 F070					A200	1		
2 pole						A201	1		
3 pole						A202	2		
4 pole						A203	2		
4 pole 1 pole preclose 6° ¹						WAA653	2		
5 pole						WAA341	3		
6 pole						A342	3		
7 pole						A343	4		
8 pole						A344	4		
8 pole 2 pole preclose 6° ¹						WAA654	4		
9 pole						WAA345	5		
10 pole						A346	5		
11 pole					WAA347	6			
12 pole					A348	6			

ON/OFF Switches with 90° Switching

[< back to table of contents >](#)

1 pole contacts	 F056					A290	1		
2 pole preclose 30°						A291	1		
3 pole						A292	2		
4 pole						A324	2		
4 pole 1 pole preclose 60° ¹						A293	2		
4 pole 3 pole preclose 30°						WAA327	2		
5 pole contacts					WAA325	3			
6 pole preclose 30°					A326	3			
3 pole 360° rotation	 F062					WAA208	2		

ON/OFF Switches with 30° Switching







































































1 pole	 F169					WAA100	1	
2 pole						WAA101	1	
3 pole						WAA102	2	
4 pole						WAA103	2	
1 pole with spring return	 F153					A204	1	
2 pole with spring return						A205	1	
3 pole with spring return						WAA206	2	
4 pole with spring return						WAA207	2	

¹for use in a three phase four-wire system with switched neutral ²not available for switch type CA25 ³not available for switch type C315

Function	Escutch. Plate	Type/Handle				Code	Stages	Connection Diagram
		CA4 CA4-1 CAD4-1	CAD.. CA10- CA25	CA10B- CA25B	CA40 C26- C315			































Double-throw Switches without „OFF“ 60° Switching

[Dimensions p.56](#)

























1 pole	 F072					A220	1		
2 pole						A221	2		
3 pole						A222	3		
4 pole						A223	4		
4 pole 1 pole preclose 6° ²						WAA673	4		4 pole 1 pole preclose 6°
5 pole						A369	5		
6 pole						A370	6		
7 pole						A371	7		
8 pole						A372	8		
8 pole 2 pole preclose 6° ²						WAA972	8		5 pole
9 pole						WAA373	9		
10 pole						WAA374	10		
11 pole					WAA375	11			
12 pole					WAA376	12			

[< back to table of contents >](#)

Double-throw Switches without „OFF“ with electrically isolated contacts

1 pole	 F072					A720	1		
2 pole						A721	2		
3 pole						A722	3		1-4 pole
4 pole						A723	4		
4 pole 1 pole preclose 6° ²						WAA973	4		4 pole 1 pole preclose 6°
1 pole with spring return	 F026					A795	1		1 pole mit Rückzug

Double-throw Switches without „OFF“ 30° Switching

































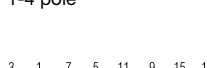











1 pole	 F026					WAA120	1		
2 pole						WAA121	2		
3 pole						WAA122	3		
4 pole						WAA123	4		1-4 pole
1 pole with spring return	 F026					A295	1		
2 pole with spring return						A296	2		
3 pole with spring return						WAA297	3		1-3 pole

¹not available for switch type CA25 ²for use in a three phase four-wire system with switched neutral

Function	Escutch. Plate	Type/Handle	Code	Stages	Connection Diagram
	CA4 CA4-1 CAD4-1	CAD.. CA10- CA25	CA10B- CA63 C80- C315		



















Double-throw Switches with Center „OFF“ 60° Switching

[Dimensions p.56](#)



























1 pole	 F071					A210	1			
2 pole						A211	2			
3 pole						A212	3			
4 pole						A213	4			
4 pole 1 pole preclose 6° ³						WAA913	4			
5 pole						A361	5			
6 pole						A362	6			
7 pole						WAA363	7			
8 pole						WAA364	8			
8 pole 2 pole preclose 6° ³					WAA664	8				
										

[< back to table of contents >](#)

Double-throw Switches with Center „OFF“ 90° Switching

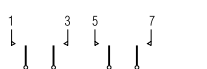
1 pole	 F057					A218	1	
2 pole						A219	2	
3 pole						WAA299	3	
4 pole 1 pole preclose 60° ³						WAA294	4	

Double-throw Switches with Center „OFF“ and electrically isolated contacts























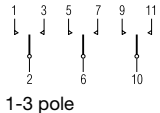

1 pole	 F071					A710	1	
2 pole						A711	2	
3 pole						A712	3	
4 pole 1 pole preclose 6° ³						A713	4	
1 pole with spring return	 F025					A714	1	
2 pole to center						A715	2	

¹switch type C315 with  handle ²not available for switch type C315 ³for use in a three phase four-wire system with switched neutral







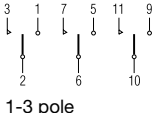















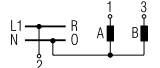
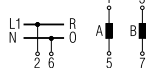
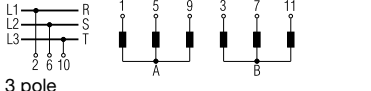











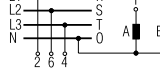

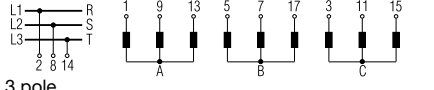











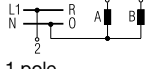
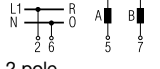
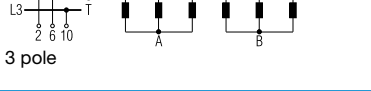

Function	Escutch. Plate	Type/Handle	Code	Stages	Connection Diagram
		CA4 CAD.. CA40 CA4-1 CA10- CA10B- C26- CAD4-1 CA25 CA25B C315			

Double-throw Switches with Spring Return to Center

[Dimensions p.56](#)

1 pole with spring return 2 pole to center 3 pole		  	       	A214 A215 A216	1 2 3	
1 pole with spring return 2 pole from left to center 3 pole		  	       	A320 A321 A322	1 2 3	

General Application Switches

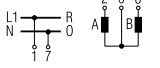
1 pole 2 Gang 2 pole Switching sequence: 3 pole 0, A, A+B		  	       	A310 A312 WAA314	1 2 3	  
1 pole 3 Gang 2 pole Switching sequence: 3 pole 0, A, A+B, A+B+C		  	       	A311 WAA313 WAA315	2 3 5	  
1 pole 2 Gang 2 pole Series switching 3 pole Switching sequence: 0, A, B, A+B		  	       	WAA330 WAA331 WAA332	1 2 3	  
2 pole 2 Gang Series-parallel Switching Switching sequence: 0, A+B series, A, A+B parallel		  	       	WAA339	2	













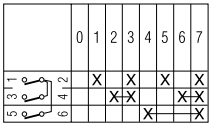



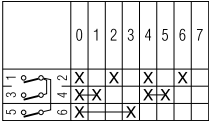



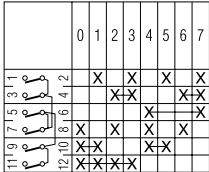



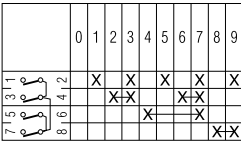



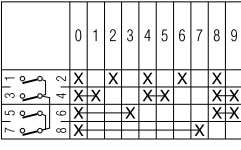

¹not available for switch type CA25 ²not available for switch type C315 ³available only up to switch type CA63

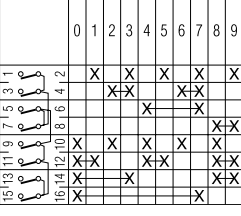
Function	Escutch. Plate	Type/Handle				Code	Stages	Connection Diagram
		CA4 CA4-1 CAD4-1	CA10 CA11 CA12	CA10B- CA25B	CA40 C26- C315			

Coding Switches/Binary Code

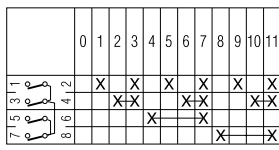
[Dimensions p.56](#)



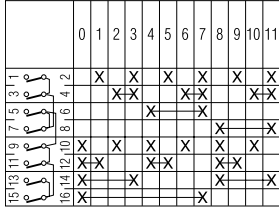































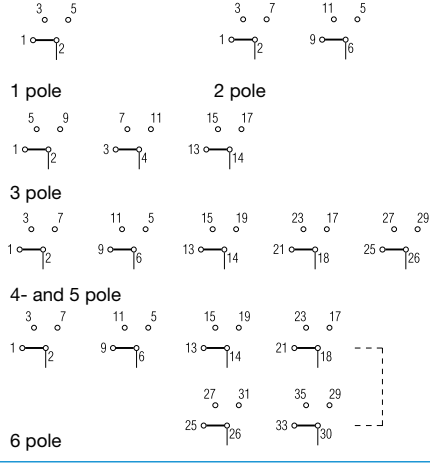

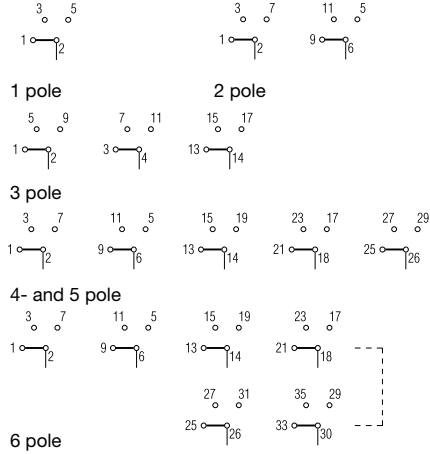























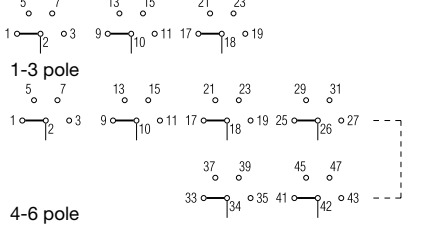



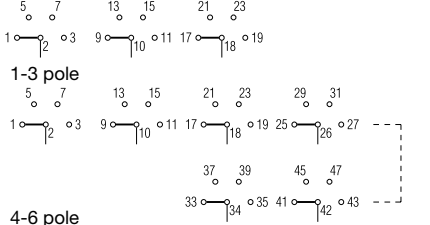













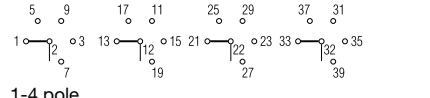













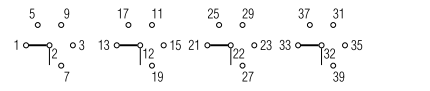













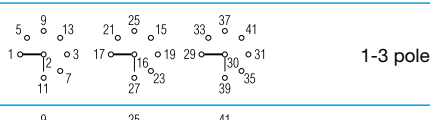













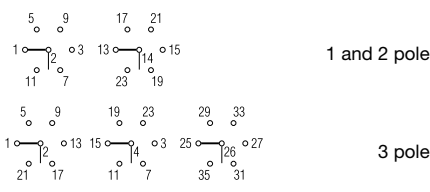









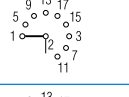









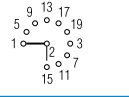







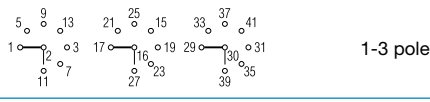

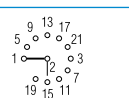

























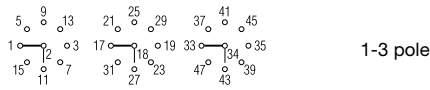





































































































< back to table of contents >

0 - 7 360° rotation	 F322				A540	2	
0 - 7 complement 360° rotation	 F322				WAA541	2	
0 - 7 + complement 360° rotation	 F322				WAA542	3	
0 - 9	 F007				A550	2	
0 - 9 complement	 F007				WAA551	2	
0 - 9 + complement	 F007				WAA552	4	
0 - 11 360° rotation	 F009				A543	2	
0 - 11 + complement 360° rotation	 F009				WAA545	4	

Function	Escutch. Plate	Type/Handle				Code	Stages	Connection Diagram
		CA4 CA4-1 CAD4-1	CAD.. CA10- CA25	CA10B- CA63	C80- C315			

Multi-step Switches without „OFF“

[Dimensions p.56](#)

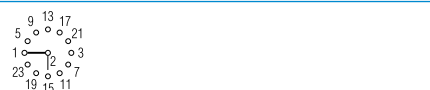













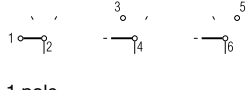

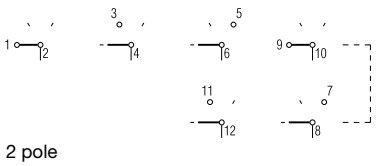

1 pole 3 Step 2 pole 3 pole 4 pole 5 pole 6 pole	 F076	      	      	      	    	A230 A250 A270 A476 WAA484 WAA489	2 3 5 6 8 9	
1 pole 4 Step 2 pole 3 pole 4 pole 5 pole 6 pole	 F077	      	      	      	    	A231 A251 A271 A477 WAA485 WAA490	2 4 6 8 10 12	
1 pole 5 Step 2 pole 3 pole 4 pole	 F078	      	      	      	    	A232 A252 WAA272 WAA478	3 5 8 10	
1 pole 6 Step 2 pole 3 pole	 F079	      	      	      	    	A233 WAA253 WAA273	3 6 9	
1 pole 7 Step 2 pole 3 pole	 F110	      	      	      	    	WAA234 WAA254 WAA274	4 7 11	
1 pole 8 Step 2 pole 3 pole	 F111	      	      	      	    	WAA235 WAA255 WAA275	4 8 12	
1 pole 9 Step	 F010	      	      	      	    	WAA236	5	
1 pole 10 Step	 F011	      	      	      	    	WAA237	5	
1 pole 11 Step	 F012	      	      	      	    	WAA238	6	
1 pole 12 Step 1 pole 360° rotation	 F013	      	      	      	    	WAA239 WAA639	6 6	

[< back to table of contents >](#)



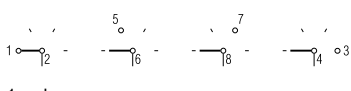



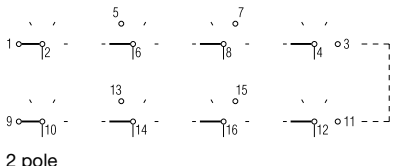



¹switch type C315 with  handle ²not available for switch type CA11B

Function	Escutch. Plate	Type/Handle	Code	Stages	Connection Diagram
	CA4 CA4-1 CAD4-1	CAD.. CA10- CA10B- CA25 CA63	C80- C315		

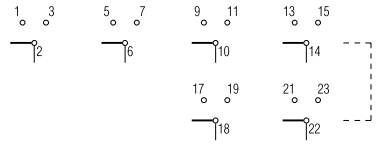
Multi-step Switches without „OFF“ with electrically isolated contacts [Dimensions p.56](#)

1 pole 3 Step						A730	2	 <p>1 pole</p>
2 pole						A750	3	 <p>2 pole</p>
1 pole 4 Step						A731	2	 <p>1 pole</p>
2 pole						A751	4	 <p>2 pole</p>

Multi-step Switches with „OFF“

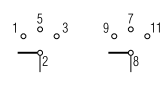
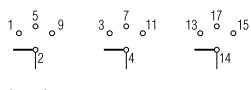
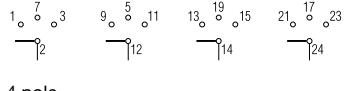
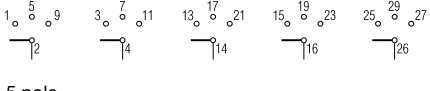













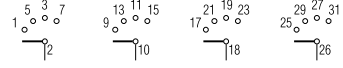





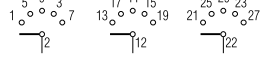





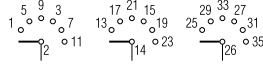





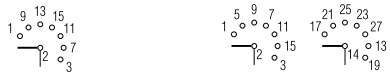













1 pole 2 Step 2 pole 3 pole 4 pole 5 pole 6 pole						A240 A260 A280 WAA480 WAA486 WAA491	1 2 3 4 5 6	 <p>1-6 pole</p>
1 pole 3 Step 2 pole 3 pole 4 pole 5 pole						A241 A261 A281 WAA481 WAA487	2 3 5 6 8	 <p>1 and 2 pole</p>  <p>3 pole</p>  <p>4 pole</p>  <p>5 pole</p>

[< back to table of contents >](#)

Function	Escutch. Plate	Type/Handle				Code	Stages	Connection Diagram
		CA4 CA4-1 CAD4-1	CAD. CA10- CA25	CA10B- CA63	C80- C315			

Multi-step Switches with „OFF“

[Dimensions p.56](#)

1 pole 4 Step 2 pole 3 pole 4 pole	 F002					A242 WAA262 WAA282 WAA482	2 4 6 8	 1-4 pole
1 pole 5 Step 2 pole 3 pole	 F003					A243 WAA263 WAA283	3 5 8	 1-3 pole
1 pole 6 Step 2 pole 3 pole	 F004					A244 WAA264 WAA284	3 6 9	 1-3 pole
1 pole 7 Step 2 pole	 F005					WAA245 WAA265	4 7	 1 pole 2 pole
1 pole 8 Step	 F006					WAA246	4	
1 pole 9 Step	 F007					WAA247	5	
1 pole 10 Step	 F008					WAA248	5	
1 pole 11 Step 1 pole 360° rotation	 F009					WAA249 WAA649	6 6	

[< back to table of contents >](#)









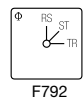

Switch Function and Configuration

C, CA, CAD Switches



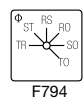



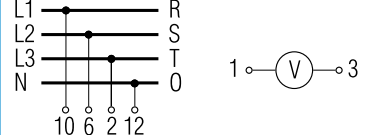



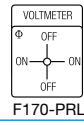

Function	Escutch. Plate	Type/Handle	Code	Stages	Connection Diagram
		CA4 CA4-1 CA10- CAD4-1 CA25 CAD..	CA10B- CA25B		

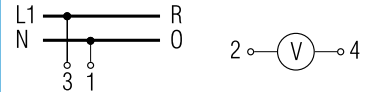
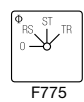
Voltmeter Switches without „OFF“

[Dimensions p.56](#)

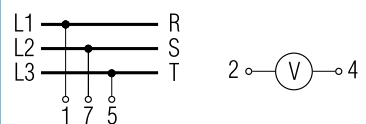
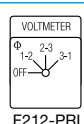
3 phase 3 wire						A023	2	
3 phase 3 wire 3 phase to phase and phase to neutral						A025	3	

Voltmeter Switches with „OFF“

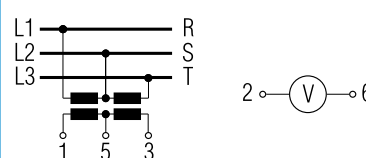













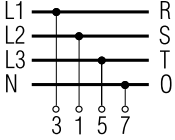





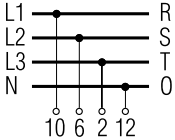



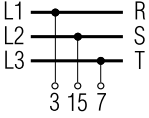
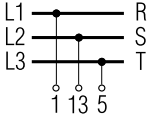

2 pole 360° rotation						WAA002	1	
3 phase 3 wire						A004	2	
						WAA011	2	

[< back to table of contents >](#)

Function	Escutch. Plate	Type/Handle				Code	Stages	Connection Diagram
		CA4 CA4-1 CAD4-1	CA10- CA25	CAD..	CA10B- CA25B			

Voltmeter Switches with „OFF“

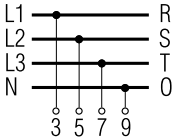
[Dimensions p.56](#)











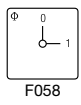



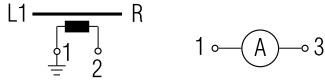
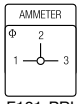



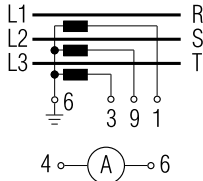
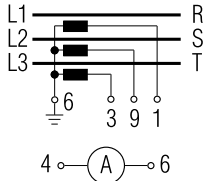



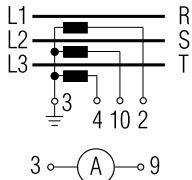
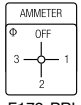
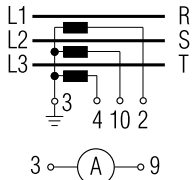
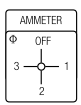

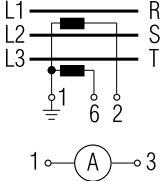
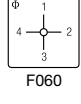
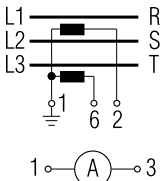
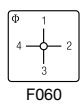
3 phase to neutral	 F779					WAA005	2	 
3 phase to phase and 3 phase to neutral	 F782					A007	3	 
2 separate 3 phase with center „OFF“	 F786					WAA008	4	   
3 phase and 1 phase to neutral	 F789					WAA010	3	 

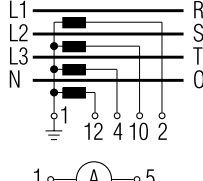
[< back to table of contents >](#)

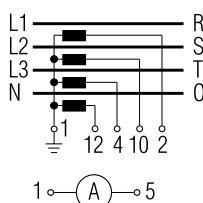
Function	Escutch. Plate	Type/Handle	Code	Stages	Connection Diagram
	CA4 CA4-1 CAD4-1	CAD.. CA10- CA25	CA10B- CA63 C32	C43- C125	

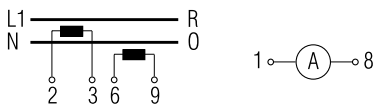
Ammeter Switches

[Dimensions p.56](#)

Single pole with one current transformer	 F058					WAA046	1	
Single pole with 3 current transformers without „OFF“	 F181-PRL					WAA017	3	
Single pole with 3 current transformers with „OFF“ 360° rotation	 F059					A048	3	
Single pole with 2 current transformers (3 readings)	 F172-PRL					WAA021	2	
Single pole with 4 current transformers	 F060					WAA036	4	
2 pole 2 current transformers	 F057					WAA037	3	











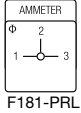

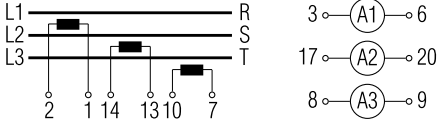
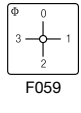

[< back to table of contents >](#)

¹available only up to switch type CA25B

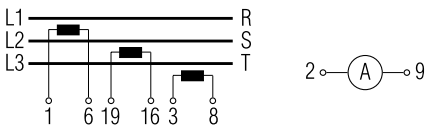
Function	Escutch. Plate	Type/Handle	Code	Stages	Connection Diagram
		CA4 CAD.. CA10B- CA4-1 CA10- CA63- CAD4-1 CA25 C42 C43- C125			

Ammeter Switches

[Dimensions p. 56](#)

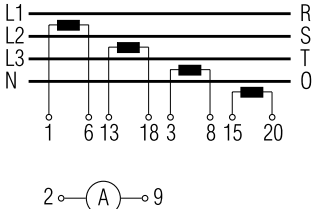













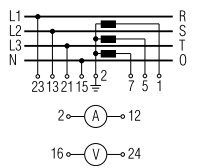





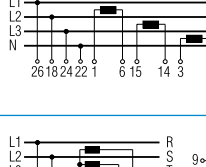

2 pole 3 current transformers	 F181-PRL				WAA019	5		
	 F059					A038	5	
2 pole 4 current transformers	 F060					WAA039	6	

¹available only up to switch type CA25B

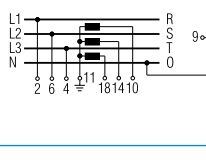
Function	Escutch. Plate	Type/Griff	C26-C43 CA40-CA63	Code	Stages	Connection Diagram
CA4 CAD.. CA4-1 CA25	CA4 CAD.. CA4-1 CA25	CA10- CA25B				





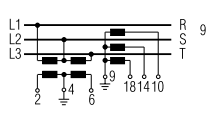









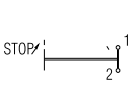





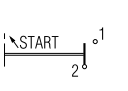





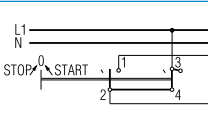





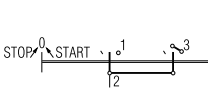

Volt-ammeter Switches

Dimensions p.56

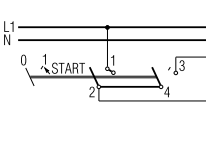
3 phase - phase to phase 3 current	 F101					WAA027	6	
	 F077					WAA028	7	
3 phase voltage 3 phase current 4 wire	 F174-PRL					WAA033	5	
3 phase voltage 3 phase current 3 wire	 F174-PRL					WAA035	5	

[< back to table of contents >](#)

Control Switches

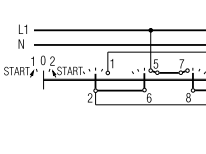









Stop switch	 F022					WAA174	1	
Start switch	 F023					A175	1	
Stop start switch single pole	 F024					A176	1	
Stop start switch 2 pole	 F024					WAA183	2	
Stop start switch with spring return from start to run	 F119					A178	1	
Stop start switch with spring return to run for 2 units	 F121					WAA177	2	

¹available only up to switch type CA25B

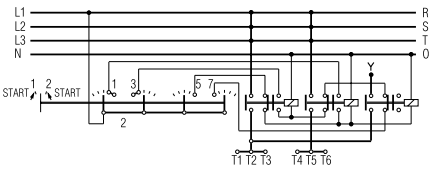













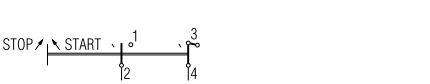





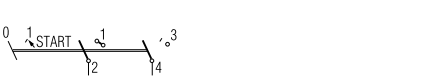



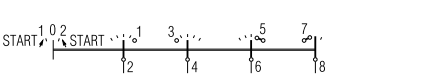

Function	Escutch. Plate	Type/Handle CA4 CAD.. CA4-1 CA10- CA10B- CAD4-1 CA25 CA25B	C26- C43 CA40- CA63	Code	Stages	Connection Diagram
----------	----------------	---	------------------------------	------	--------	--------------------

Control Switches



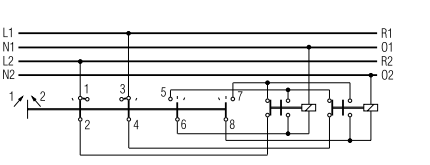

Dimensions p.56

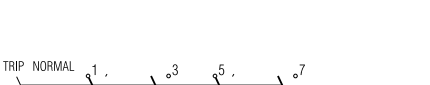
Stop start switch with spring return to run with contactor interlock contactors for 2 units	 F121					WAA182	2	
Motor voltage control switch	 F144-PRL					WAA150	2	

Control Switches with electrically isolated contacts

Stop start switch single pole	 F024					A789	1	
Stop start switch with spring return to 1	 F119					A791	1	
Stop start switch with spring return to run for 2 units	 F121					WAA790	2	
Contactor control with spring return to „OFF“	 F025					WAA179	2	
Circuit breaker control	 F143-PRL					WAA537	2	

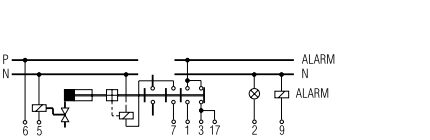
Control and Alarm Switches¹

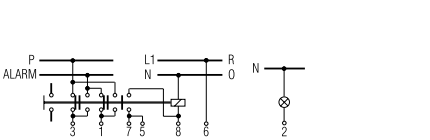
With slip clutch and without indicator device						WAA190	5 ³	
Without indicator device						WAA192	2	

¹Advise the indicator device, described in Catalog 101, page 9. ²not available for switch types CA25 and CA25B ³incl. slip clutch
⁴available only up to switch type CA40

Function	Escutch. Plate	Type/Handle				Code	Stages	Connection Diagram
		CA4 CA4-1 CAD4-1	CAD. CA10- CA25	CA..B C26-C43 CA40-CA63	C80- C315			

Motor Reversing Switches

[Dimensions p.56](#)

2 pole						A400	2	
3 pole						A401	3	
3 pole with spring return to „OFF“						A228	3	
3 pole for use with reversing contactors						WAA402	4	

[< back to table of contents >](#)

Motor Control Switches















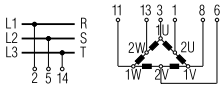





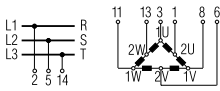





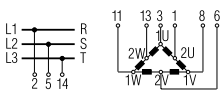



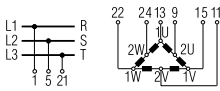

2 speed 2 winding 0-A-BY or Δ						WAA451	3	
3 speed 2 winding 0-A-BY or Δ						WAA457	6	

¹not available for switch type CA25 ²not available for switch types C26-C43, CA40-CA63 ³available only up to switch type CA50

Function	Escutch. Plate	Type/Handle	Code	Stages	Connection Diagram
		CA4 CAD.. CA40 CA4-1 CA10- CA26- CAD4-1 CA25 CA25B C315			

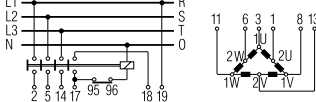
Motor Control Switches

[Dimensions p. 56](#)

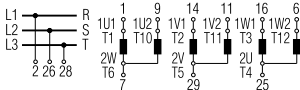
2 speed single winding	 F073					A440	4	
2 speed single winding without „OFF“	 F072					A466	4	
2 speed single winding with center „OFF“	 F071					A441	4	
2 speed single winding reversing	 F105					A442	6	
2 speed single winding for use with contactors	 F073					WAA444	5	
2 speed reversing for 2 way operation with slip clutch for „OFF“ load use	 F294					WAA468	10 ¹	

¹incl. slip clutch

[< back to table of contents >](#)

Function	Escutch. Plate	Type/Handle				Code	Stages	Connection Diagram
		CA4 CA4-1 CAD4-1	CAD. CA10- CA25	CA..B C26-C43 CA40-CA63	C80- C315			

Star-delta Switches

[Dimensions p.56](#)

OFF-star-delta						A410	4	
Reversing						WAA413	5	
With auxiliary contact closed in „OFF“ position						WAA416	5	
For use with reversing contactors						A419	4	

[< back to table of contents >](#)

Start and Run Switches

Split-phase start						A425	2	
Split-phase start reversing						WAA426	3	
Split-phase reversing auto cutout of start field winding						WAA622	3	

¹not available for switch type CA25

Function/Type	Escutch. Plate	Handle	Code	Stages	Double Latching	Connection Diagram	L350 L630 L1000	L351 L631
---------------	----------------	--------	------	--------	-----------------	--------------------	-----------------------	--------------

ON/OFF Switches with 60° Switching

[Dimensions p. 56](#)

1 pole 2 pole 3 pole 4 pole	L350			WAA200 WAA201 WAA202 WAA203	1 2 3 4			1-4 pole
1 pole 2 pole 3 pole 4 pole	L351			WAA200 WAA201 WAA202 WAA203	1 2 3 4			1-4 pole
1 pole 2 pole 3 pole 4 pole	L400			WAA200 WAA201 WAA202 WAA203	2 2 4 4			1-4 pole
3 pole with lugs suitable for protective cover	L400			WAA302	3			WAA302
1 pole 2 pole 3 pole 4 pole	L600			WAA200 WAA201 WAA202 WAA203	3 3 6 6			1-4 pole
1 pole 2 pole 3 pole 4 pole	L630			WAA200 WAA201 WAA202 WAA203	2 4 6 8	● ●		1-4 pole
1 pole 2 pole 3 pole 4 pole	L631			WAA200 WAA201 WAA202 WAA203	2 4 6 8	● ●		1-4 pole
1 pole 2 pole 3 pole 4 pole	L800			WAA200 WAA201 WAA202 WAA203	2 4 6 8			1-4 pole
1 pole 2 pole 3 pole 4 pole	L1000			WAA200 WAA201 WAA202 WAA203	3 6 9 12	● ● ●		1-4 pole
1 pole 2 pole 3 pole	L1200			WAA200 WAA201 WAA202	3 6 9			1-3 pole
1 pole 2 pole 3 pole	L1600			WAA200 WAA201 WAA202	4 8 12			1-3 pole
1 pole 2 pole	L2000			WAA200 WAA201	5 10	●		1 and 2 pole

[< back to table of contents >](#)

Function/Type	Escutch. Plate	Handle	Code	Stages	Double Latching	Connection Diagram	L350 L630 L1000	L351 L631
---------------	----------------	--------	------	--------	-----------------	--------------------	-----------------------	--------------

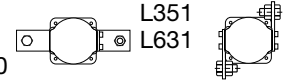

ON/OFF Switches with 90° Switching

[Dimensions p. 56](#)

1 pole 2 pole 3 pole 4 pole	L350 1 pole preclose 60°			WAA290 WAA291 WAA292 WAA293	1 2 3 4			1-4 pole
1 pole 2 pole 3 pole 4 pole	L351 1 pole preclose 60°			WAA290 WAA291 WAA292 WAA293	1 2 3 4			1-4 pole
1 pole 2 pole 3 pole 4 pole	L400 1 pole preclose 60°			WAA290 WAA291 WAA292 WAA293	2 2 4 4			1-4 pole
3 pole 3 pole	with lugs suitable for protective cover 360° rotation	 	 	WAA307 WAA208	3 4		 	WAA307
1 pole 2 pole 3 pole 4 pole	L600 1 pole preclose 60°			WAA290 WAA291 WAA292 WAA293	3 3 6 6		 	1-3 pole 4 pole
1 pole 2 pole 3 pole 4 pole	L630 1 pole preclose 60°			WAA290 WAA291 WAA292 WAA293	2 4 6 8		 	1-3 pole 4 pole
1 pole 2 pole 3 pole 4 pole	L631 1 pole preclose 60°			WAA290 WAA291 WAA292 WAA293	2 4 6 8		 	1-3 pole 4 pole
1 pole 2 pole 3 pole 4 pole	L800 1 pole preclose 60°			WAA290 WAA291 WAA292 WAA293	2 4 6 8	● ● ●	 	1-3 pole 4 pole
1 pole 2 pole 3 pole 4 pole	L1000 1 pole preclose 60°			WAA290 WAA291 WAA292 WAA293	3 6 9 12	● ● ●	 	1-3 pole 4 pole
1 pole 2 pole 3 pole	L1200			WAA290 WAA291 WAA292	3 6 9	● ● ●		1-3 pole
1 pole 2 pole 3 pole	L1600			WAA290 WAA291 WAA292	4 8 12	● ● ●		1-3 pole
1 pole 2 pole	L2000			WAA290 WAA291	5 10	● ●		1- und 2 pole

[< back to table of contents >](#)

● Additional length for switches size S2 for mounting E/EF = 27 mm
 ● Additional length for switches size S3 for mounting E/EF = 31,5 mm and mounting ER/VE = 20,1 mm

Function/Type	Escutch. Plate	Handle	Code	Stages	Double Latching	Connection Diagram	L350 L630 L1000	L351 L631
---------------	----------------	--------	------	--------	-----------------	--------------------	-----------------------	--------------

Double-throw Switches without „OFF“ 60° Switching Dimensions p. 56

1 pole 2 pole 3 pole 4 pole	L350			WAA220 WAA221 WAA222 WAA223	2 4 6 8			1-4 pole
1 pole 2 pole 3 pole 4 pole	L351			WAA220 WAA221 WAA222 WAA223	2 4 6 8			1-4 pole
1 pole 2 pole 3 pole 4 pole	L400			WAA220 WAA221 WAA222 WAA223	2 4 6 8			1-4 pole
1 pole 2 pole 3 pole 4 pole	L600			WAA220 WAA221 WAA222 WAA223	3 6 9 12	● ●		1-4 pole
1 pole 2 pole 3 pole	L630			WAA220 WAA221 WAA222	4 8 12	●		1-3 pole
1 pole 2 pole 3 pole	L631			WAA220 WAA221 WAA222	4 8 12	●		1-3 pole
1 pole 2 pole 3 pole	L800			WAA220 WAA221 WAA222	4 8 12	●		1-3 pole
1 pole 2 pole	L1000			WAA220 WAA221	6 12	●		1 and 2 pole
1 pole	L1200			WAA220	6			
1 pole	L1600			WAA220	8			
1 pole	L2000			WAA220	10			

[< back to table of contents >](#)

Switch Function and Configuration

L Switches

Function/Type	Escutch. Plate	Handle	Code	Stages	Double Latching	Connection Diagram	L350 L630 L1000	L351 L631
---------------	----------------	--------	------	--------	-----------------	--------------------	-----------------------	--------------

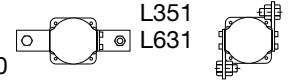

Double-throw Switches with Center „OFF“ 60° Switching Dimensions p.56

1 pole 2 pole 3 pole 4 pole	L350			WAA210 WAA211 WAA212 WAA213	2 4 6 8			1-4 pole
1 pole 2 pole 3 pole 4 pole	L351			WAA210 WAA211 WAA212 WAA213	2 4 6 8			1-4 pole
1 pole 2 pole 3 pole 4 pole	L400			WAA210 WAA211 WAA212 WAA213	2 4 6 8			1-4 pole
1 pole 2 pole 3 pole 4 pole	L600			WAA210 WAA211 WAA212 WAA213	3 6 9 12	● ●		1-4 pole
1 pole 2 pole 3 pole	L630			WAA210 WAA211 WAA212	4 8 12	●		1-3 pole
1 pole 2 pole 3 pole	L631			WAA210 WAA211 WAA212	4 8 12	●		1-3 pole
1 pole 2 pole 3 pole	L800			WAA210 WAA211 WAA212	4 8 12	●		1-3 pole
1 pole 2 pole	L1000			WAA210 WAA211	6 12	●		1 and 2 pole
1 pole	L1200			WAA210	6			
1 pole	L1600			WAA210	8			
1 pole	L2000			WAA210	10			

[< back to table of contents >](#)

● Additional length for switches size S2 for mounting E/EF = 27 mm
 ● Additional length for switches size S3 for mounting E/EF = 31,5 mm and mounting ER/VE = 20,1 mm











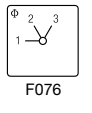

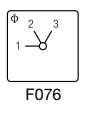

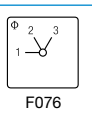

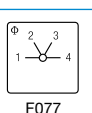

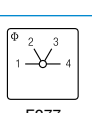

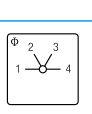

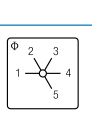
Switch Function and Configuration

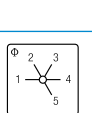
L Switches

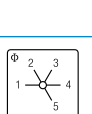
Function/Type	Escutch. Plate	Handle	Code	Stages	Double Latching	Connection Diagram	L350 L630 L1000	L351 L631
---------------	----------------	--------	------	--------	-----------------	--------------------	-----------------------	--------------

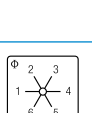
Multi-step Switches single pole without „OFF“

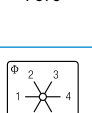
[Dimensions p. 56](#)

3 Step	L350			WAA230	4			
3 Step	L351			WAA230	4			
3 Step	L400			WAA230	4			
4 Step	L350			WAA231	4			
4 Step	L351			WAA231	4			
4 Step	L400			WAA231	4			
5 Step	L350			WAA232	6			
5 Step	L351			WAA232	6			
5 Step	L400			WAA232	6			
6 Step	L350			WAA233	6			
6 Step	L351			WAA233	6			

[< back to table of contents >](#)

Function/Type	Escutch. Plate	Handle	Code	Stages	Double Latching	Connection Diagram	L350 L630 L1000	L351 L631
---------------	----------------	--------	------	--------	-----------------	--------------------	-----------------------	--------------

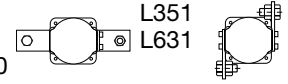

Multi-step Switches single pole without „OFF“

[Dimensions p.56](#)

6 Step	L400			WAA233	6			
7 Step	L350			WAA234	8			
7 Step	L351			WAA234	8			
7 Step	L400			WAA234	8			
8 Step	L350			WAA235	8			
8 Step	L351			WAA235	8			
8 Step	L400			WAA235	8			
9 Step	L350			WAA236	10			
9 Step	L351			WAA236	10			
9 Step	L400			WAA236	10			
10 Step	L350			WAA237	10			

[< back to table of contents >](#)

























Switch Function and Configuration

L Switches

Function/Type	Escutch. Plate	Handle	Code	Stages	Double Latching	Connection Diagram	L350 L630 L1000	L351 L631
---------------	----------------	--------	------	--------	-----------------	--------------------	-----------------------	--------------

Multi-step Switches single pole without „OFF“

[Dimensions p.56](#)

10 Step	L351			WAA237	10		
10 Step	L400			WAA237	10		
11 Step	L350			WAA238	12		
11 Step	L351			WAA238	12		
11 Step	L400			WAA238	12		
12 Step	L350			WAA239	12		
12 Step	L351			WAA239	12		
12 Step	L400			WAA239	12		



[< back to table of contents >](#)

<p>Two Hole Panel Mount or Mosaic Mount</p>	<p>Terminals rotated 90°</p>	<p>Code</p>	<p>CA4 CA4-1 CAD4-1</p>
--	------------------------------	--------------------	---------------------------------

[< back to table of contents >](#)

<p>Panel Mount</p> <div style="display: flex; align-items: flex-start;"> <div style="flex: 1;">  <p>Two hole, Protection IP 40</p> </div> <div style="flex: 1;">  <p>Two hole Protection IP 66/67/69k</p> </div> <div style="flex: 1;">  <p>Two hole with shaft for radio knobs, Protection IP 40 Shaft diam. 6 mm/.24 inch</p> <p>Shaft diam. 6.35 mm/.25 inch, Protection IP 40</p> </div> </div>		<p>●</p> <p>●</p> <p>●</p> <p>●</p>	<p>E E-V</p> <p>EF EF-V</p> <p>E9</p> <p>E91</p>	<p>●</p> <p>●</p> <p>●</p> <p>●</p>
<p>Mosaic Mount</p> <div style="display: flex; align-items: flex-start;"> <div style="flex: 1;">  <p>For Siemens-Mosaic 30 mm grid depth, Protection IP 40</p> </div> <div style="flex: 1;">  <p>For Subklew-, Kreutzenbeck-, Symo-Mosaic, Protection IP 40 28 mm 25 mm 25 mm grid depth</p> </div> <div style="flex: 1;">  <p>For Mauell-Mosaic 30 mm grid depth, Protection IP 40</p> </div> </div>			<p>E92</p> <p>E93</p> <p>E94</p>	<p>●</p> <p>●</p> <p>●</p>

Two or Four Hole Panel Mount	Terminals rotated 90°	Code	CAD.. CA10- CA25	CA10B- CA63 C42	C43 C80- C200-4 L350 Size S2	C315 L400- L2000 Size S3
-------------------------------------	-----------------------	-------------	------------------------	-----------------------	--	-----------------------------------

<p>Panel Mount</p>  <p>Four hole, Protection IP 40</p> <p>Four hole, Protection IP 66/67/69k</p> <p>Two hole, Protection IP 66/69k</p>	<p>●</p> <p>●</p> <p>●</p>	<p>E E-V</p> <p>EF EF-V</p> <p>E22 E22-V</p>	<p>●</p> <p>●</p> <p>●</p>	<p>●</p> <p>●</p> <p>●</p>	<p>●</p> <p>●</p> <p>●</p>	<p>●</p> <p>●</p> <p>●</p>
<p>Panel mount using larger face plate, handle and heavy duty stop</p>  <p>Four hole, Protection IP 40</p> <p>Four hole, Protection IP 66/67/69k</p>		<p>EG</p> <p>EGF</p>	<p>●</p> <p>●</p>	<p>CA40- CA63</p> <p>CA40- CA63</p>	<p>C80- C200-4</p> <p>C80- C200-4</p>	
<p>Double End Mount</p>  <p>Four hole, Protection IP 40</p> <p>Four hole, Protection IP 66/67/69k</p>		<p>ER</p> <p>ERF</p>	<p>●</p> <p>●</p>	<p>CAD.. CA10- CA25</p> <p>CAD.. CA10- CA25</p>	<p>●</p> <p>●</p>	<p>●</p> <p>●</p>

[< back to table of contents >](#)

Two or Four Hole Panel Mount	Code	CAD.. CA10- CA25	CA10B CA11B CA20B CA25B	C32 C42 CA40 CA50 CA63	C43
-------------------------------------	-------------	------------------------	----------------------------------	------------------------------------	-----

[< back to table of contents >](#)

	<p>Panel mount with heavy duty latching and metal shaft</p> <p>Four hole, Protection IP 40 48 x 48 Plate – S0</p>	KN2	●			
	<p>Four hole, Protection IP 40 64 x 64 Plate – S1</p>	KN1	●	●	●	
	<p>Four hole, Protection IP 40 64 x 64 Plate – S1 complete with 6mm square metal shaft</p>	KD1	●	●	●	
<p>Panel mount with protective cover</p>						
	<p>Four hole Protection front IP 40 rear IP 30</p>	EC	CAD.. CA10- CA25	●		
	<p>Four hole with additional shaft seal Protection front IP 65 rear IP 30</p>	ED	CAD.. CA10- CA25	●		
	<p>Four hole Protection front IP 40 rear IP 42</p>	EC1		●		
	<p>Four hole with additional shaft seal Protection front IP 65 rear IP 42</p>	ED1		●		
	<p>Two hole Protection front IP 66/69k rear IP 42</p>	ED22	CAD.. CA10- CA25			





Single Hole Mount	Terminals rotated 90°	Code	CA4 CA4-1 CAD4-1	CAD.. CA10- CA25
-------------------	-----------------------	------	------------------------	------------------------

		Code	mm	mm
 <p>Single Hole Mount complete with lock nut and shaft seal Bezel mount, Protection IP 66/67/69k</p>	●	FS1 FS1-V	16/22 16/22	22
 <p>Square face plate, Protection IP 66/67/69k</p>	●	FT1 FT1-V	22	22
 <p>S1 square face plate and heavy duty stop, Protection IP 66/67/69k</p>	●	FT3 FT3-V	22/30 22/30	22/30 22/30
 <p>S1 square face plate and heavy duty stop, Protection IP 66/67/69k</p>	●	FS2 FS2-V	16/22 16/22	22
 <p>S1 square face plate and heavy duty stop, Protection IP 66/67/69k</p>	●	FT2 FT2-V	22	22
 <p>S1 square face plate and heavy duty stop, Protection IP 66/67/69k</p>	●	FT4 FT4-V	22/30 22/30	22/30 22/30
 <p>S1 square face plate and heavy duty stop, Protection IP 66/67/69k</p>	●	FH3 FH3-V	22	22
 <p>Rectangular face plate, Protection IP 66/67/69k</p>	●	FS4 FS4-V	16/22 16/22	22
 <p>S1 rectangular face plate and heavy duty stop, Protection IP 66/67/69k</p>	●	FT6 FT6-V	22	22
 <p>S1 rectangular face plate and heavy duty stop, Protection IP 66/67/69k</p>	●	FH4 FH4-V	22	22
 <p>Lock nut spanner</p>		S00 T170 09		

[< back to table of contents >](#)

Base Mount	Terminals rotated 90°	Code	CAD.. CA10- CA25	CA10B- CA63 C42	C43 C80- L2000
------------	-----------------------	------	------------------	-----------------	----------------

[< back to table of contents >](#)

Base Mount						
	<p>Four hole, Protection IP 40</p>	●	<p>VE VE-V</p>	<p>CAD.. CA10- CA25</p>	● ●	●
	<p>Four hole with integrated simplified door clutch, Protection IP 65</p>	●	<p>VF VF-V</p>	<p>CAD.. CA10- CA25</p>		
	<p>Two hole, Protection IP 40</p>	●	<p>VE22 VE22V</p>	<p>● CAD.. CA10- CA25</p>		
	<p>Two hole with integrated simplified door clutch, Protection IP 65</p>	●	<p>VF22 VF22V</p>	<p>● CAD.. CA10- CA25</p>		
	<p>Snap-on for DIN Rail EN 60715, Protection IP 40</p>		<p>VE1</p>	<p>●</p>	<p>●</p>	

Base Mount	Code	CA4 CA4-1 CAD4-1	CAD.. CA10- CA25
-------------------	-------------	------------------------	------------------------

DIN Rail Mount



Snap-on for DIN Rail EN 60715 with face plate for 45 mm standard knock-out.

VE2



Snap-on for DIN Rail EN 60715. With face plate for 45 mm standard knock-out. The handle and plate are adjustable in height.

VE21





CAD..
CA10-
CA20

VE21V

CA25

[< back to table of contents >](#)

<p>Mounting Plates for Plaster Depth Boxes acc. to DIN 49073 and ÖNORM E8608</p>	<p>Code</p>	<p>CAD.. CA10- CA25</p>
---	--------------------	---------------------------------

	<p>Plaster depth trim, Protection IP 40</p>	<p>UE1</p>	<p>●</p>
	<p>With light, Protection IP 40</p>	<p>UE2</p>	<p>●</p>
	<p>With facility for light addition, Protection IP 40</p>	<p>UE3</p>	<p>●</p>

< back to table of contents >

Face plates



Square and rectangular face plates are available for each size of switch. The face plate consists of a frame and a faceplate having the switch positions which is then embossed with hot-foil backing. The face plate frame is an essential part of the switch and serves as a bearing surface for the handle. If the switch is to be mounted without a face plate we would recommend for size S1, S2 and S3 the handle bearing plate T100-04.

Standard Letterings Available

(Over 500 standard letterings, special letterings upon request.)

30° switching

F022	F141	F158	F703	F023	F137	F142	F159	F701	F704	F152	F709	F026	F035	F153	F169	F024	F143
F160	F221	F222	F224	F025	F034	F036	F037	F038	F039	F139	F144	F147	F149	F150	F151	F219	F258
F259	F273	F280	F329	F384	F708	F053	F161	F297	F298	F306	F307	F001	F040	F052	F229	F355	F018
F019	F029	F030	F154	F155	F165	F166	F183	F184	F301	F302	F321	F332	F333	F334	F335	F374	F711
F712	F002	F021	F033	F041	F055	F305	F319	F054	F003	F042	F138	F255	F299	F308	F353	F350	F351
F004	F014	F017	F020	F027	F028	F031	F032	F043	F049	F135	F156	F157	F162	F167	F168	F187	F189
F303	F304	F336	F337	F347	F348	F710	F713	F714	F734	F005	F044	F136	F140	F702	F006	F010	F045
F015	F050	F007	F011	F046	F008	F012	F047	F016	F051	F009	F013	F048	F748				

45° switching

F747	F295	F742	F743	F215	F216	F738	F744	F746	F792	F793	F107	F109	F114	F115	F212	F213	F214
F217	F267	F289	F330	F375	F376	F383	F408	F409	F410	F411	F412	F413	F426	F427	F430	F729	F752
F775	F776	F777	F778	F779	F780	F781	F796	F797	F798	F105	F108	F112	F113	F117	F118	F293	F429
F739	F741	F419	F789	F790	F791	F794	F795	F110	F106	F116	F294	F317	F414	F415	F416	F417	F418
F782	F783	F784	F785	F786	F787	F788	F799	F111	F210	F211	F284	F285	F296	F322	F727	F740	

← back to table of contents →

Face plates

60° switching

F707	F708	F708	F709	F713	F717	F718	F722	F723	F724	F725	F726	F727	F728	F729	F730	F731	F732	F733	F734	F735	F736	F737	F738	F739	F740	F741	F742	F743	F744	F745	F746	F747	F748	F749	F750	F751	F752	F753	F754	F755	F756	F757	F758	F759	F760	F761	F762	F763	F764	F765	F766	F767	F768	F769	F770	F771	F772	F773	F774	F775	F776	F777	F778	F779	F780	F781	F782	F783	F784	F785	F786	F787	F788	F789	F790	F791	F792	F793	F794	F795	F796	F797	F798	F799	F800	F801	F802	F803	F804	F805	F806	F807	F808	F809	F810	F811	F812	F813	F814	F815	F816	F817	F818	F819	F820	F821	F822
------	------	------	------	------	------	------	------	------	------	------	------	------	------	------	------	------	------	------	------	------	------	------	------	------	------	------	------	------	------	------	------	------	------	------	------	------	------	------	------	------	------	------	------	------	------	------	------	------	------	------	------	------	------	------	------	------	------	------	------	------	------	------	------	------	------	------	------	------	------	------	------	------	------	------	------	------	------	------	------	------	------	------	------	------	------	------	------	------	------	------	------	------	------	------	------	------	------	------	------	------	------	------	------	------	------	------	------

[< back to table of contents >](#)

90° switching





F907	F908	F909	F910	F911	F912	F913	F914	F915	F916	F917	F918	F919	F920	F921	F922	F923	F924	F925	F926	F927	F928	F929	F930	F931	F932	F933	F934	F935	F936	F937	F938	F939	F940	F941	F942	F943	F944	F945	F946	F947	F948	F949	F950	F951	F952	F953	F954	F955	F956	F957	F958	F959	F960	F961	F962	F963	F964	F965	F966	F967	F968	F969	F970	F971	F972	F973	F974	F975	F976	F977	F978	F979	F980	F981	F982	F983	F984	F985	F986	F987	F988	F989	F990	F991	F992	F993	F994	F995	F996	F997	F998	F999	F1000	F1001	F1002	F1003	F1004	F1005	F1006	F1007	F1008	F1009	F1010	F1011	F1012	F1013	F1014	F1015	F1016	F1017	F1018	F1019	F1020	F1021	F1022	F1023	F1024	F1025	F1026	F1027	F1028	F1029	F1030	F1031	F1032	F1033	F1034	F1035	F1036	F1037	F1038	F1039	F1040	F1041	F1042	F1043	F1044	F1045	F1046	F1047	F1048	F1049	F1050	F1051	F1052	F1053	F1054	F1055	F1056	F1057	F1058	F1059	F1060	F1061	F1062	F1063	F1064	F1065	F1066	F1067	F1068	F1069	F1070	F1071	F1072	F1073	F1074	F1075	F1076	F1077	F1078	F1079	F1080	F1081	F1082	F1083	F1084	F1085	F1086	F1087	F1088	F1089	F1090	F1091	F1092	F1093	F1094	F1095	F1096	F1097	F1098	F1099	F1100	F1101	F1102	F1103	F1104	F1105	F1106	F1107	F1108	F1109	F1110	F1111	F1112	F1113	F1114	F1115	F1116	F1117	F1118	F1119	F1120	F1121	F1122	F1123	F1124	F1125	F1126	F1127	F1128	F1129	F1130	F1131	F1132	F1133	F1134	F1135	F1136	F1137	F1138	F1139	F1140	F1141	F1142	F1143	F1144	F1145	F1146	F1147	F1148	F1149	F1150	F1151	F1152	F1153	F1154	F1155	F1156	F1157	F1158	F1159	F1160	F1161	F1162	F1163	F1164	F1165	F1166	F1167	F1168	F1169	F1170	F1171	F1172	F1173	F1174	F1175	F1176	F1177	F1178	F1179	F1180	F1181	F1182	F1183	F1184	F1185	F1186	F1187	F1188	F1189	F1190	F1191	F1192	F1193	F1194	F1195	F1196	F1197	F1198	F1199	F1200	F1201	F1202	F1203	F1204	F1205	F1206	F1207	F1208	F1209	F1210	F1211	F1212	F1213	F1214	F1215	F1216	F1217	F1218	F1219	F1220	F1221	F1222	F1223	F1224	F1225	F1226	F1227	F1228	F1229	F1230	F1231	F1232	F1233	F1234	F1235	F1236	F1237	F1238	F1239	F1240	F1241	F1242	F1243	F1244	F1245	F1246	F1247	F1248	F1249	F1250	F1251	F1252	F1253	F1254	F1255	F1256	F1257	F1258	F1259	F1260	F1261	F1262	F1263	F1264	F1265	F1266	F1267	F1268	F1269	F1270	F1271	F1272	F1273	F1274	F1275	F1276	F1277	F1278	F1279	F1280	F1281	F1282	F1283	F1284	F1285	F1286	F1287	F1288	F1289	F1290	F1291	F1292	F1293	F1294	F1295	F1296	F1297	F1298	F1299	F1300	F1301	F1302	F1303	F1304	F1305	F1306	F1307	F1308	F1309	F1310	F1311	F1312	F1313	F1314	F1315	F1316	F1317	F1318	F1319	F1320	F1321	F1322	F1323	F1324	F1325	F1326	F1327	F1328	F1329	F1330	F1331	F1332	F1333	F1334	F1335	F1336	F1337	F1338	F1339	F1340	F1341	F1342	F1343	F1344	F1345	F1346	F1347	F1348	F1349	F1350	F1351	F1352	F1353	F1354	F1355	F1356	F1357	F1358	F1359	F1360	F1361	F1362	F1363	F1364	F1365	F1366	F1367	F1368	F1369	F1370	F1371	F1372	F1373	F1374	F1375	F1376	F1377	F1378	F1379	F1380	F1381	F1382	F1383	F1384	F1385	F1386	F1387	F1388	F1389	F1390	F1391	F1392	F1393	
------	------	------	------	------	------	------	------	------	------	------	------	------	------	------	------	------	------	------	------	------	------	------	------	------	------	------	------	------	------	------	------	------	------	------	------	------	------	------	------	------	------	------	------	------	------	------	------	------	------	------	------	------	------	------	------	------	------	------	------	------	------	------	------	------	------	------	------	------	------	------	------	------	------	------	------	------	------	------	------	------	------	------	------	------	------	------	------	------	------	------	------	------	-------	-------	-------	-------	-------	-------	-------	-------	-------	-------	-------	-------	-------	-------	-------	-------	-------	-------	-------	-------	-------	-------	-------	-------	-------	-------	-------	-------	-------	-------	-------	-------	-------	-------	-------	-------	-------	-------	-------	-------	-------	-------	-------	-------	-------	-------	-------	-------	-------	-------	-------	-------	-------	-------	-------	-------	-------	-------	-------	-------	-------	-------	-------	-------	-------	-------	-------	-------	-------	-------	-------	-------	-------	-------	-------	-------	-------	-------	-------	-------	-------	-------	-------	-------	-------	-------	-------	-------	-------	-------	-------	-------	-------	-------	-------	-------	-------	-------	-------	-------	-------	-------	-------	-------	-------	-------	-------	-------	-------	-------	-------	-------	-------	-------	-------	-------	-------	-------	-------	-------	-------	-------	-------	-------	-------	-------	-------	-------	-------	-------	-------	-------	-------	-------	-------	-------	-------	-------	-------	-------	-------	-------	-------	-------	-------	-------	-------	-------	-------	-------	-------	-------	-------	-------	-------	-------	-------	-------	-------	-------	-------	-------	-------	-------	-------	-------	-------	-------	-------	-------	-------	-------	-------	-------	-------	-------	-------	-------	-------	-------	-------	-------	-------	-------	-------	-------	-------	-------	-------	-------	-------	-------	-------	-------	-------	-------	-------	-------	-------	-------	-------	-------	-------	-------	-------	-------	-------	-------	-------	-------	-------	-------	-------	-------	-------	-------	-------	-------	-------	-------	-------	-------	-------	-------	-------	-------	-------	-------	-------	-------	-------	-------	-------	-------	-------	-------	-------	-------	-------	-------	-------	-------	-------	-------	-------	-------	-------	-------	-------	-------	-------	-------	-------	-------	-------	-------	-------	-------	-------	-------	-------	-------	-------	-------	-------	-------	-------	-------	-------	-------	-------	-------	-------	-------	-------	-------	-------	-------	-------	-------	-------	-------	-------	-------	-------	-------	-------	-------	-------	-------	-------	-------	-------	-------	-------	-------	-------	-------	-------	-------	-------	-------	-------	-------	-------	-------	-------	-------	-------	-------	-------	-------	-------	-------	-------	-------	-------	-------	-------	-------	-------	-------	-------	-------	-------	-------	-------	-------	-------	-------	-------	-------	-------	-------	-------	-------	-------	-------	-------	-------	-------	-------	-------	-------	-------	-------	-------	-------	-------	-------	-------	-------	-------	-------	-------	-------	-------	-------	-------	-------	-------	-------	-------	-------	-------	-------	-------	-------	-------	-------	-------	-------	-------	-------	-------	-------	-------	-------	-------	-------	-------	-------	-------	-------	-------	-------	-------	-------	-------	-------	-------	-------	-------	-------	--

Handles

Type	Color	Code	Size
			S00 S0 S1 S2 S3









Type	Color	Code	Size
			S00 S0 S1 S2 S3

<p>R-Handle</p> 	black red	G001 G002	— ● ● ● ● — ● ● ● ●
<p>F-Handle</p> 	black red	G221 G222	● ● ● ● — ● ● ● ● —
<p>S-Handle</p>  <p>S0 S1</p>	black red	G301 G302	— ● ● — — — ● ● — —
<p>P-Handle</p>  <p>S0 S1-S3</p>	black red	G211 G212	— ● ● ● ● — ● ● ● ●
<p>Handwheel</p> 	black	G971	— — — — ●

<p>I-Handle</p>  <p>S00 S0-S3</p>	black red	G251 G252	● ● ● ● ● ● ● ● ● ●
<p>B-Handle</p> 	black red	G521 G522	— ● ● — — — ● ● — —
<p>L-Handle</p> 	black red	G501 G502	— — ● — — — — ● — —
<p>K-Handle</p> 	black red	G411 G412	— — ● ● ● — — ● ● ●
<p>O-Handle</p> 	black red	G321 G322	— — ● — — — — ● — —

[< back to table of contents >](#)

International Standards and Approvals

Country	Authority	Mark or Standard	CAD11/12	CA10	CA10B	CA25	C26	CA40	C43	C315	L350/1	L400	L1200
			CA4	CA11	CA11B	CA25B	C32	CA50	C80	C316	L630/1	L600	L1600
			CA4-1	CA20	CA20B	CA25B	C42	CA63	C125		L1000	L800	L2000
USA	Underwriters Laboratories Inc.	 ¹								●	●	●	●
		 ² ³	●	●	●	●	●	●	●	●		●	
Canada	UL investigated acc. to CSA	 ⁵	●	●	●	●	●		●	●	●	●	●
		 ¹									●	●	●
		 ² ³	●	●	●	●	●	●	●	●			●
International Electrical Commission (IEC) Recommendation		IEC 60947 ⁴	+	+	+	+	+	+	+	+	+	+	+
China	China Quality Certification Centre	 GB/T14048.3	●	●	●	●	●		●	●			
Russia Belarus Kazakhstan	Eurasian Conformity		●	●	●	●	●	●	●	●	●	●	●
Russian Federation	Russian Maritime Register of Shipping		●	●	●	●							
Lloyds Register EMEA			●	●	●								
<p>● Switch approved + Switch conforms to requirements</p> <p>¹Approved under the "Component Program" (UL-Recognized Industrial Component). File No. E35541, Category Control No. NLRV2 (U.S.) and NLRV8 (Canada) resp. File No. E60262, Category Control Number NRNT2 (U.S.) and NRNT8 (Canada).</p> <p>²Approved under the "Listing Program". File No. E35541, Category Control No. NLRV (U.S.) resp. NLRV7 (Canada).</p> <p>³Switch types CAD11/CAD12 approved under the "Listing Program". File No. E60262, Category Control No. NRNT (U.S.) resp. NRNT7 (Canada).</p> <p>⁴IEC does not operate an approval scheme.</p> <p>⁵File No. 13002ass No. 3211-05 resp. 4652-04.</p>													

[< back to table of contents >](#)

Selection Data	CA4 CA10 CA11 CA20 CA25 C42 C315
	CA4-1 CA10B CA11B CA20B CA25B C26 C32 C43 CA40 CA50 CA63 C80 C125 C200-4 C316

Rated Insulation Voltage U_i	IEC 60947-3, EN 60947-3 ¹ VDE 0660 part 107 ¹	V	440	690	690	690	690	690	690	690	690	690	690	690	690	690	690	1000
	SEV ⁴	V	380	660	660	660	690	660	660	660	690	690	690	660	660	-	660	
	UL/Canada	V	300	300	600	600	300	600	600	600	600	600	600	600	600	-	600	
	CEE/NEMKO	V	400/380	380	400	400	-	400	400	400	-	-	-	400	-	-	-	
	min. voltage																	on request
Rated Impulse Withstand Voltage U_{imp}		kV	4	6	6	6	6	6	6	6	6	6	6	6	6	6	6	6/8
Rated Thermal Current I_U/I_{th}	IEC 60947-3, EN 60947-3 VDE 0660 part 107	A	10	20	20	25	32	32	50	63	40	50	63	115	150	200	315	
	SEV ³ 380 V	A	10	16	16	25	32	32	40	63	40	50	63	100	150	-	315	
	660 V	A	-	12	12	25	32	32	40	63	40	50	63	-	-	-	315	
	UL/Canada	A	10	20	20	30	30	40	50	65	45	55	65	100	150	-	240	
Rated Operational Current I_e	AC-21A Switching of resistive loads, including moderate overloads	IEC 60947-3, EN 60947-3 VDE 0660 690 V	A	10	20	20	25	32	32	40	63	40	50	63	100	150	200	315
	AC-1 Resistive or low inductive loads	SEV ⁴ 380 V 660 V	A	10	16	16	25	32	32	40	63	40	50	63	100	150	-	315
			A	-	12	12	20	32	32	40	63	40	50	63	-	-	-	315
AC-22A Switching of combined resistive or low inductive loads including moderate overloads	IEC 60947-3, EN 60947-3 VDE 0660 220 V-500 V	A	10	20	20	25	32	32	40	63	40	50	63	100	150	150	315	
	part 107 660 V-690 V	A	-	20	20	25	32	32	40	63	40	50	63	100	125	125	125	
AC-15 Switching of control devices, contactors, valves etc.	IEC 60947-5-1, EN 60947-5-1 VDE 0660 220 V-240 V	A	2,5	6	6	8	12	14	16	-	14	16	16	-	-	-	-	
	part 200 380 V-440 V	A	1,5	4	4	5	6	6	7	-	6	7	7	-	-	-	-	
Pilot Duty	UL/Canada ³ Heavy	VAC	A300	A300	A600	A600	A300	A600	A600	A600	A600	A600	A600	-	-	-	A600	
Ampere Rating Resistive or low inductive loads	UL/Canada ³	A	10	20	20	30	30	40	50	65	45	55	60	100	150	-	240	
Resistive load/motor load	CEE	A	4/2	10/6	10/6	16/10	-	25/1032/10	40/10	-	-	-	63/10	-	-	-	-	
	NEMKO	A	6/4 ²	10/6	-	20/10	-	-	-	-	-	-	-	-	-	-	-	
Breaking capacity	220 V-240 V	A	50	150	150	200	280	280	380	550	290	330	440	860	1100	1100	2000	
	380 V-440 V	A	50	150	150	200	250	250	360	550	290	330	440	860	1100	1100	2000	
	660 V-690 V	A	-	80	80	125	150	150	270	365	170	200	260	400	490	490	340	
Power loss per contact at I_U		W	0,4/0,9	0,9	0,9	0,9	0,7	1,3	1,3	1,7	1	1,8	2,8	5,8	3,8	6,7	17	
Resistance to vibration			min. 4 g, 2-100 Hz, 1,6 mm									on request						
Resistance to shock			min. 5 g, 6 ms									min. 5 g, 30 ms						
Short Circuit Protection	Max. fuse size (gG-characteristic)	A	10	25	25	35	35	50	63	80	50	63	63	125	200	200	315	
	Rated short-time withstand current (1s-current)	A	60	140	140	280	480	350	800	1000	950	950	950	1300	2000	2000	4200	
Min. Ambient Temperature of Stages			-25 °C (valid only without optional extra, C315/C316 on request)															
Max. Ambient Temperature of Stages ^{5,7} open at 100 % I_U/I_{th} enclosed at 100 % I_{the}			55 °C during 24 hours with peaks up to 60 °C															
			35 °C during 24 hours with peaks up to 40 °C															

[< back to table of contents >](#)

44 ¹Valid for lines with grounded common neutral termination, overvoltage category III, pollution degree 3. Values for other supply systems on request.
²Valid for CA4 only. ³International Standards and Approvals, refer to page 43. ⁴For electromagnetic optional extras see additional data in Catalog 101.
⁵Storage temperature: -40 °C to 85 °C (in case of temperature below -5 °C no shock load permissible).

Selection Data	CA4 CA10 CA11 CA20 CA25 C42 C315
	CA4-1 CA10B CA11B CA20B CA25B C26 C32 C43 CA40 CA50 CA63 C80 C125 C200-4 C316

[< back to table of contents >](#)

Rated Utilization Category		IEC 60947-3, EN 60947-3 VDE 0660 part 107																		
AC-2	Slip ring motor starting, reversing and plugging, star-delta starting CA4-CA50	3 phase	220 V-240 V	kW	2,5	4	4	5,5	7,5	8	10	18,5	10	11	18,5	30	37	37	55	
		3 pole	380 V-440 V		4,5	7,5	7,5	11	15	15	18,5	30	18,5	22	30	40	45	55	55	90
			500 V		-	10	10	15	18,5	18,5	22	40	22	30	40	55	75	75	110	
			660 V-690 V		-	10	10	13	15	15	22	37	22	30	37	55	55	55	55	
AC-3	Direct-on-line starting, star-delta starting CA63-C315	3 phase	220 V-240 V	kW	1,5	3	3	4	5,5	5,5	7,5	11	7,5	11	11	15	22	22	37	
		3 pole	380 V-440 V		2,2	5,5	5,5	7,5	11	11	15	18,5	15	18,5	18,5	30	37	37	55	
			500 V		-	5,5	5,5	7,5	11	11	15	18,5	15	18,5	18,5	30	37	37	55	
			660 V-690 V		-	5,5	5,5	7,5	11	11	15	18,5	15	18,5	22	30	30	30	37	
		1 phase	110 V-120 V	kW	0,3	0,6	0,6	1,5	2,2	2,2	2,5	3	2,5	3	3	3,7	5,5	5,5	11	
		2 pole	220 V-240 V		0,55	2,2	2,2	3	4	4	5,5	6	5,5	6	6	7,5	11	11	22	
			380 V-440 V		0,75	3	3	3,7	5,5	5,5	7,5	11	7,5	11	11	13	18,5	18,5	30	
AC-4	Direct-on-line starting, reversing, plugging and inching	3 phase	220 V-240 V	kW	0,37	0,55	0,55	1,5	2,5	2,7	3,7	5,5	3,7	4	5,5	6	10	10	15	
		3 pole	380 V-440 V		0,55	1,5	1,5	3	5,5	5,5	6	7,5	6	7	7,5	11	15	15	25	
			500 V		-	1,5	1,5	3	5,5	5,5	6	7,5	6	7	7,5	11	15	15	25	
			660 V-690 V		-	1,5	1,5	3	5,5	5,5	6	7,5	6	7,5	9	11	15	15	22	
		1 phase	110 V-120 V	kW	0,15	0,3	0,3	0,45	0,75	0,75	1,1	1,2	1,1	1,2	1,2	1,5	2,2	2,2	4	
		2 pole	220 V-240 V		0,25	0,75	0,75	1,1	1,5	1,5	2,2	2,4	2,2	2,4	2,4	3	4	4	7,5	
			380 V-440 V		0,5	1,5	1,5	2,2	3	3	3,7	4	3,7	4	4	5,5	7,5	7,5	11	
AC-23A	Frequent switching of motors or other high inductive loads	3 phase	220 V-240 V	kW	1,8	3,7	3,7	5,5	7,5	7,5	11	15	7,5	11	15	30	37	37	75	
		3 pole	380 V-440 V		3	7,5	7,5	11	15	15	22	30	18,5	22	30	45	75	75	132	
			500 V		-	7,5	7,5	11	15	15	30	45	18,5	22	30	55	90	90	132	
			660 V-690 V		-	7,5	7,5	11	15	15	22	40	18,5	22	30	45	55	55	37	
		1 phase	110 V-120 V	kW	0,37	0,75	0,75	1,5	2,2	2,2	2,5	4	2,2	2,5	4	5,5	11	11	18,5	
		2 pole	220 V-240 V		0,75	2,5	2,5	3	4	4	5,5	10	4	5,5	10	15	22	22	37	
			380 V-440 V		1,1	3,7	3,7	5,5	7,5	7,5	11	18,5	7,5	11	18,5	22	37	37	55	
Ratings		UL/Canada																		
	Standard motor load DOL-Rating (similar AC-3)	3 phase	110 V-120 V	HP	0,75	1,5	1,5	3	5	5	7,5	7,5	7,5	7,5	7,5	10	15	-	30	
		3 pole	220 V-240 V		1	3	3	7,5	10	10	15	15	15	15	15	20	25	-	75	
			440 V-480 V		-	-	5	10	-	20	25	25	25	30	30	40	40	-	75	
			550 V-600 V		-	-	5	10	-	25	30	30	25	30	30	40	50	-	60	
		1 phase	110 V-120 V	HP	0,33	0,5	0,5	1,5	2	2	3	3	3	3	3	5	7,5	-	15	
		2 pole	220 V-240 V		0,75	1	1	3	5	5	7,5	7,5	7,5	7,5	10	15	-	40		
			277 V		0,75	2	2	3	5	5	7,5	7,5	7,5	7,5	10	10	15	-	40	
			440 V-480 V		-	-	2	5	-	10	15	15	15	15	15	20	25	-	50	
			550 V-600 V		-	-	2	5	-	15	20	20	15	20	20	25	30	-	50	
	Heavy motor load Reversing-Rating (similar AC-4)	3 phase	110 V-120 V	HP	-	0,5	0,5	1	2	2	3	5	-	-	-	7,5	10	-	15	
		3 pole	220 V-240 V		-	1	1	2	3	3	5	7,5	-	-	-	15	20	-	30	
			440 V-600 V		-	-	3	5	-	10	15	20	-	-	-	25	30	-	40	
					1 phase	110 V-120 V	HP	-	0,17	0,17	0,33	1,5	1,5	1,5	2	-	-	-	3	5
		2 pole	220 V-240 V		-	0,5	0,5	0,75	3	3	3	5	-	-	-	7,5	10	-	15	
			277 V		-	0,6	0,6	1	3	3	3	5	-	-	-	7,5	10	-	15	

Selection Data	CA4 CA10 CA11 CA20 CA25 C42 C315
	CA4-1 CA10B CA11B CA20B CA25B C26 C32 C43 CA40 CA50 CA63 C80 C125 C200-4 C316

Max. Permissible Wire Gage - Use copper wire only																					
Single-core or stranded wire	mm ²	2x	2x	2x	2x	2x	2x	2x	2x	16	16	16	16	35	70	95 ¹	185 ¹				
	AWG	14	12	12	10	8	8	8	6	6	6	6	6	2	2/0	-	MCM 350				
Flexible wire (sleeving in accordance with DIN 46228) Flexible AWG wires (without sleeve)	mm ²	2x	2x	2x	2x	2x	2x	2x	2x	10	10	10	10	25	50	95 ¹	150 ¹				
	AWG	(1)	(2,5)	(2,5)	(2,5)	(4)	(4)	(6)	(10)	(10)	(10)	(10)	(10)	(25)	(50)	-	MCM 300				
Tightening torque of screws																					
	Nm	0,4	0,6	0,6	1,3	1,3	1,3	2,2	3	1,8	1,8	1,8	4	4,5	8	14					
	lb-in	3,5	5	5	12	12	12	19,5	26,4	16	16	16	35	39,8	70	125					
DC Switching Capacity²																					
contacts in series:	1 2 3 4 5 6 8																				
	Permissible voltage in volts																				
Utilization category DC-21A	24 48 72 96 120 144 192	A	10	16	16	21	24	26	32	35	40	63									
Switching of resistive load	48 96 144 192 240 288 384	A	6	14	15	18	24	25	32	32	40	63									
Time constant L/R≤1ms	60 120 180 240 300 360 480	A	5	13	15	17	21	24	28	28	40	50									
	110 220 330 440 550 660 -	A	4	6	7	6	7	7	9,3	-	-	-									
	220 440 660 - - - -	A	0,8	0,9	1	1	1	1	1	-	-	-									
Utilization category DC-22A	24 48 72 96 120 144 192	A	8	14	15	18	24	25	32	35	40	63									
Switching of mixed resistive and inductive load	48 96 144 192 240 288 384	A	5	13	15	17	24	25	32	32	40	63									
f.e. shunt motors	60 120 180 240 300 360 480	A	4	12	15	16	19	24	25	-	20	25									
Time constant L/R≤2,5ms	110 220 330 440 550 660 -	A	1,5	1,9	2	2	2	2,25	3	-	-	-									
	220 440 660 - - - -	A	0,3	0,3	0,35	0,3	0,35	0,35	0,35	-	-	-									
Utilization category DC-23A	24 48 72 96 120 144 192	A	7	13	15	16	23	23	32	35	40	63									
Switching of highly inductive loads	48 96 144 192 240 288 384	A	4	12	15	15	23	21	32	26	40	63									
f.e. series motors	60 120 180 240 300 360 480	A	3,5	10	13	14	16	18	25	-	-	-									
Time constant L/R≤15ms	110 220 330 440 550 660 -	A	1	1,5	1,75	1,7	1,75	2	2,5	-	-	-									
	220 440 660 - - - -	A	0,2	0,2	0,3	0,2	0,3	0,2	0,3	-	-	-									
Utilization category DC-13	24 48 - - - - -	A	0,8	3	-	4	-	5	-	-	-	-									
Control of electromagnets	48 96 - - - - -	A	0,5	1,7	-	2,4	-	3	-	-	-	-									
Time constant L/R≤100ms	60 120 - - - - -	A	0,2	1,4	-	1,8	-	2,5	-	-	-	-									
	110 220 - - - - -	A	-	0,7	-	1	-	1,5	-	-	-	-									
	220 440 - - - - -	A	-	0,15	-	0,35	-	0,5	-	-	-	-									

¹Cable lug must accept M8 (C200-4) and M12 (C315/C316) screw. ²Values for switches with spring return on request.

Ring cable lug – Dimensions		A (mm)	B (mm)	C (mm)	H (mm)
	C26-6	10	M4	5	3,7
	C32-6	12,9	M5	6,1	3,8
	C42-6	15,6	M6	7,1	4,1
	C80-6	23,1	M6	9,1	5,4
	C125-6	28,5	M6	11,8	4,9
	C200-4	-	M8	-	4,8
	C315	23,6	M12	18,3	3,4

< back to table of contents >

Selection Data	L350				L630						
	L351	L400	L600	L631	L800	L1000	L1200	L1600	L2000		

[< back to table of contents >](#)

Rated Insulation Voltage U_i	IEC 60947-3, EN 60947-3 ¹ VDE 0660 part 107 ¹		V	690	690	690	690	690	690	690	690	690	
	UL/Canada ²		V	600	600	600	600	600	600	600	600	600	
	min. voltage		V	on request									
Rated Impulse Withstand Voltage U_{imp}			kV	6	6	6	6	6	6	6	6	6	
Rated Thermal Current I_u/I_{th}	IEC 60947-3, EN 60947-3 VDE 0660 part 107												
	Ambient temp. +35 °C during 24 hours with peaks up to +40 °C		A	350	500	800	630	1100	1000	1450	1900	2400	
	Ambient temp. +55 °C during 24 hours with peaks up to +60 °C		A	350	500	750	600	950	920	1300	1700	2000	
UL/Canada ²		A	350	400	630	630	800	1000	1200	1600	2000		
Rated Operational Current I_e													
AC-20A No-load operation	IEC 60947-3, EN 60947-3 VDE 0660 part 107		690 V	A	350	500	800	630	1100	1000	1450	1900	2400
	Occasional switching under load $\cos \varphi 0,8$	3 phase, 3 pole	220 V-440 V	A	350	500	800	500	1000	630	1200	1200	1200
			500 V	A	350	450	500	450	630	500	800	800	800
		1 phase, 2 pole	660 V-690 V	A	315	350	400	360	400	400	400	400	400
AC-21B Switching of resistive loads, including moderate overloads	3 phase, 3 pole	220 V-440 V	A	250	450	500	350	630	400	800	800	800	
		500 V	A	250	400	450	315	500	350	630	630	630	
	1 phase, 2 pole	660 V-690 V	A	200	300	350	250	350	300	350	350	350	
Interrupting Rating	UL/Canada ²		600 V	A	200	300	300	200	300	200	300	200	200
	CSA		600 V	A	200	200	200	200	200	200	200	200	200
Rated Utilization Category	IEC 60947-3, EN 60947-3 VDE 0660 part 107												
AC-23B Occasional switching of motors or other high inductive loads	3 phase	220 V-240 V	kW	45	75	75	45	75	45	75	75	75	
	3 pole	380 V-440 V	kW	90	132	132	90	132	90	132	132	132	
		500 V	kW	110	132	132	110	132	110	132	132	132	
		660 V-690 V	kW	55	55	65	65	65	65	65	65	65	
Short Circuit Protection													
Max. fuse size	(aR-characteristic)		A	400	500	800	630	1100	1000	2x800	2x1000	2x1250	
Rated short-time withstand current	(1s-current)		A	on request									
Terminals													
	for connection screw length		mm	M12	M12	M16	M16	M16	M16	M16	2xM16	4xM16	
				20	30	40	30	40	40	40	40	50	50
Tightening torque of screws													
			Nm	25	25	25	25	25	25	25	25	25	
			lb-in	220	220	220	220	220	220	220	220	220	
Min. Ambient Temperature of Stages				-5 °C (-25 °C on request)									
Max. Ambient Temperature of Stages ^{3, 4}				55 °C during 24 hours with peaks up to 60 °C, permissible load see Rated Thermal Current.									

¹Valid for lines with grounded common neutral termination, overvoltage category III, pollution degree 3. Values for other supply systems on request.

²International Standards and Approvals, refer to page 43. ³For electromagnetic optional extras see additional data in Catalog 101. ⁴Storage temperature: -40 °C to 85 °C (in case of temperature below -5 °C no shock load permissible).

Selection Data	CAD4-1	CAD11	CAD12
-----------------------	--------	-------	-------

Rated Insulation Voltage U_i	IEC 60947-3, EN 60947-3 ¹ VDE 0660 part 107 SEV ² North America min. voltage	V V V V	440 – 300 1 ⁷	600 600 300 1	600 600 300 6
Rated Impulse Withstand Voltage U_{imp}				on request	
Rated Thermal Current I_U/I_{th}	IEC 60947-3, EN 60947-3 VDE 0660 part 107 SEV ² Nordamerika	A A A	5 – 5	6 5 6	6 5 6
Rated Operational Current I_e	IEC 60947-3, EN 60947-3 VDE 0660 part 107 North America ³				
AC-21A Switching of resistive loads, including moderate overloads	1 V/6 V 12 V/24 V 48 V/110 V 220 V/400 V 440 V/500 V 600 V	A A A A A A	5/2 1,2/0,7 0,45/0,25 0,15/– 0,1/– –	6/3 2/1 0,8/0,4 0,2/0,13 0,1/0,08 0,05	–/6 5/5 4/3 2/1,3 1/0,8 0,5
AC-1 Resistive or low inductive loads	SEV ² 1 V/6 V 12 V/24 V 48 V/110 V 220 V/380 V 440 V/500 V 600 V	A A A A A A	– – – – – –	5/3 2/1 0,8/0,4 0,2/0,13 0,1/0,08 0,05	–/5 5/5 4/3 2/1,3 1/0,8 0,5
Power loss per contact at I_U		W	0,4	0,5	0,2
Short Circuit Protection					
Max. fuse size	(gG-characteristic)	A	5	6	6
Rated short-time withstand current	(1s-current)	A	30	35	50
DC Switching Capacity⁵	IEC 60947-3, EN 60947-3 VDE 0660 part 107 SEV ² North America ³				
DC-1 Resistive load T = 1 ms	1 V/6 V 12 V/24 V 48 V/60 V 110 V/220 V 240 V/500 V 600 V	A A A A A A	3/1,2 0,7/0,4 0,25/0,2 0,13/– 0,08/– –	4/2,5 1,5/0,8 0,3/0,27 0,2/0,1 0,08/0,03 0,02	–/4 3/2,2 1,2/1 0,6/0,3 0,25/0,1 0,1
Max. Permissible Wire Gage - Use copper wire only					
Single-core or stranded wire		mm ² AWG	2x 1,5 14	2x 2,5 12	2x 2,5 12
Flexible wire (sleeving in accordance with DIN 46228) Flexible AWG wires (without sleeve)		mm ² AWG	2x 1,5 (1) 16	2x 2,5 (2,5) 14	2x 2,5 (2,5) 14
Tightening torque of screws		Nm lb-in	0,4 3,5	0,6 5	0,6 5
Min. Ambient Temperature of Stages Max. Ambient Temperature of Stages^{4,6}	open at 100 % I_U/I_{th} enclosed at 100 % I_{the}		-25 °C (valid only without optional extra) 55 °C during 24 hours with peaks up to 60 °C 35 °C during 24 hours with peaks up to 40 °C		

[< back to table of contents >](#)

¹Valid for lines with grounded common neutral termination, overvoltage category III, pollution degree 3. Values for other supply systems on request.
²International Standards and Approvals, refer to page 43. ³Max. 300 V. ⁴For electromagnetic optional extras see additional data in Catalog 101.
⁵Values for switches with spring return on request. ⁶Storage temperature: -40 °C to 85 °C (in case of temperature below -5 °C no shock load permissible).
⁷Values with lower voltages on request.

Two or Four Hole Panel Mounting

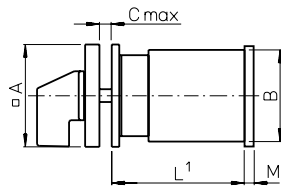

E
for CA4, CA4-1,
CAD4-1

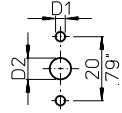

E-V
for CA4, CA4-1,
CAD4-1

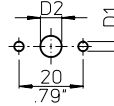

E-V
ER

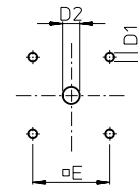

	CA10				CA10B						CA40 ³		C125		L switches		L switches	
	CA4	CA11			CA10B						CA40 ³		C125		L switches		L switches	
	CA4-1	CAD11	CA20	CA25 ³	CA20B	CA25B	C26	C32	C42 ³	C43	CA50 ³	CA63 ³	C80	C200-4	Size S2	Size S3		
A	0 1.18	48 1.89	48 1.89	48 (64) 1.89 (2.52)	64 2.52	64 2.52	64 2.52	64 2.52	64 (88) 2.52 (3.46)	88 3.46	64 (88) 2.52	88 3.46	88 (3.46)	88 3.46	88 3.46	88 3.46	130 4.96	130 4.96
B	29,5 1.16	43 1.69	45 1.77	46 1.81	56 2.20	56 2.20	58 2.28	60 2.36	66 2.60	84 3.30	55,5x64 2.19x2.52	84 3.30	88 3.46	88 3.46	88 3.46	88 3.46	126 4.96	126 4.96
C	4 .16	4 .16	4 .16	4 .16	4 .16	4 .16	4 .16	4 .16	4 .16	5,5 .22	4 .16	5,5 .22	5,5 .22	5,5 .22	5,5 .22	5,5 .22	7 .28	7 .28
D1	3,2 .13	5 .20	5 .20	5 .20	5 .20	5 .20	5 .20	5 .20	5 (6) .20 (.24)	6 .24	5 (6) .20 (.24)	6 .24	6 .24	6 .24	6 .24	6 .24	7 .28	7 .28
D2	8-11 .31-.43	8-19 .31-.75	8-19 .31-.75	8-19 .31-.75	10-22 .39-.87	10-22 .39-.87	10-22 .39-.87	10-22 .39-.87	10-22 .39-.87	13-30 .51-1.18	10-22 .39-.87	13-30 .51-1.18	13-30 .51-1.18	13-30 .51-1.18	13-30 .51-1.18	13-30 .51-1.18	15,5-25 .61-.98	15,5-25 .61-.98
E	-	36 1.42	36 1.42	36 (48) 1.42 (1.89)	48 1.89	48 1.89	48 1.89	48 1.89	48 (68) 1.89 (2.68)	68 2.68	48 (68) 1.89 (2.68)	68 2.68	68 2.68	68 2.68	68 2.68	68 2.68	104 4.09	104 4.09
M²	-	4,5 .18	4,5 .18	5,5 .22	5 .20	5,5 .22	7,5 .30	7,5 .30	7,5 .30	7,5 .30	7,6 .30	9,4 .37	27,5 1.08	27,5 1.08	27,5 1.08	27,5 1.08	11,9 (32) .47 (1.26)	11,9 (32) .47 (1.26)

²M, additional length for mounting ER only
³Dimensions in () for ER mounting plate only

⁴Dimensions in () for L800, L1200, L1600

back to table of contents >

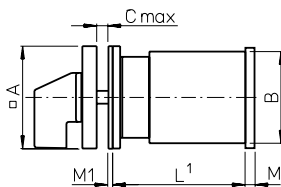

EF
for CA4, CA4-1,
CAD4-1

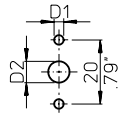

EF-V
for CA4, CA4-1,
CAD4-1

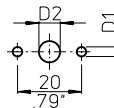

EF
EF-V
ERF

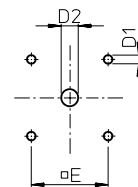

	CA10				CA10B						CA40 ³		C125		L switches		L switches	
	CA4	CA11			CA10B						CA40 ³		C125		L switches		L switches	
	CA4-1	CAD11	CA20	CA25 ³	CA20B	CA25B	C26	C32	C42 ³	C43	CA50 ³	CA63 ³	C80	C200-4	Size S2	Size S3		
A	30 1.18	48 1.89	48 1.89	48 (64) 1.89 (2.52)	64 2.52	64 2.52	64 2.52	64 2.52	64 (88) 2.52 (3.46)	88 3.46	64 (88) 2.52 (3.46)	88 3.46	88 3.46	88 3.46	88 3.46	88 3.46	130 5.12	130 5.12
B	29,5 1.16	43 1.69	45 1.77	46 1.81	56 2.20	56 2.20	58 2.28	60 2.36	66 2.60	84 3.30	55,5x64 2.19x2.52	84 3.30	88 3.46	88 3.46	88 3.46	88 3.46	126 4.96	126 4.96
C	4 .16	4 .16	4 .16	4 .16	4 .16	4 .16	4 .16	4 .16	4 .16	5,5 .22	4 .16	5,5 .22	5,5 .22	5,5 .22	5,5 .22	5,5 .22	7 .28	7 .28
D1	3,2 .13	5 .20	5 .20	5 .20	5 .20	5 .20	5 .20	5 .20	5 (6) .20 (.24)	6 .24	5 (6) .20 (.24)	6 .24	6 .24	6 .24	6 .24	6 .24	7 .28	7 .28
D2	8-11 .31-.43	15-19 .59-.75	15-19 .59-.75	15-19 .59-.75	19-22 .75-.87	19-22 .75-.87	19-22 .75-.87	19-22 .75-.87	19-22 .75-.87	26-30 1.02-1.18	19-22 .75-.87	26-30 1.02-1.18	26-30 1.02-1.18	26-30 1.02-1.18	26-30 1.02-1.18	26-30 1.02-1.18	22-25 .87-.98	22-25 .87-.98
E	-	36 1.42	36 1.42	36 (48) 1.42 (1.89)	48 1.89	48 1.89	48 1.89	48 1.89	48 (68) 1.89 (2.68)	68 2.68	48 (68) 1.89 (2.68)	68 2.68	68 2.68	68 2.68	68 2.68	68 2.68	104 4.09	104 4.09
M²	-	4,5 .18	4,5 .18	5,5 .22	5 .20	5,5 .22	7,5 .30	7,5 .30	7,5 .30	7,5 .30	7,6 .30	9,4 .37	27,5 1.08	27,5 1.08	27,5 1.08	27,5 1.08	11,9 (32) .47 (1.26)	11,9 (32) .47 (1.26)
M1	1 .04	-	-	-	-	-	-	-	-	-	-	-	-	-	-	-	-	-

²M, additional length for mounting ERF only
³Dimensions in () for ERF mounting plate only

⁴Dimensions in () for L800, L1200, L1600

¹see page 56

Two or Four Hole Panel Mounting

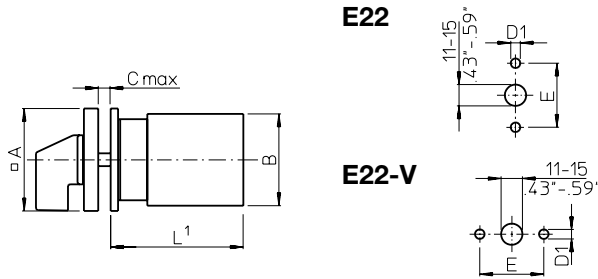

	CA10	CA11	CAD11	CA20	CA25
A	48 1.89	48 1.89		48 1.89	48 1.89
B	43 1.69	45 1.77		46 1.81	46 1.81
C	4 .16	4 .16		4 .16	4 .16
D1	5 .20	5 .20		5 .20	5 .20
E	30 1.17	30 1.17		30 1.17	30 1.17

**EG
EGF**

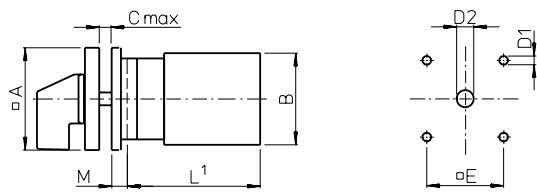

	CA10	CA11	CAD11	CA20	CA25	C26	C32	C42	CA40	CA50	CA63	C80	C125	C200-4
													L switches	Size S2
A	64 2.52	64 2.52		64 2.52	64 2.52	88 3.46	88 3.46	88 3.46	88 3.46	88 3.46	88 3.46	130 5.12	130 5.12	130 5.12
B	43 1.69	45 1.77		46 1.81	46 1.81	58 2.28	60 2.36	66 2.60	55,5x64 2.19x2.52	84 3.30	84 3.30	84 3.30	88 3.46	88 3.46
C	4 .16	4 .16		4 .16	4 .16	5.5 .22	5.5 .22	5.5 .22	5.5 .22	5.5 .22	5.5 .22	7 .28	7 .28	7 .28
D1	5 .20	5 .20		5 .20	5 .20	6 .24	6 .24	6 .24	6 .24	6 .24	6 .24	7 .28	7 .28	7 .28
D2	10-22 .39-.87	10-22 .39-.87		10-22 .39-.87	10-22 .39-.87	13-30 .51-1.18	13-30 .51-1.18	13-30 .51-1.18	13-30 .51-1.18	13-30 .51-1.18	13-30 .51-1.18	15,5-25 .61-.98	15,5-25 .61-.98	15,5-25 .61-.98
D2	19-22 .75-.87	19-22 .75-.87		19-22 .75-.87	19-22 .75-.87	26-30 1.02-1.18	26-30 1.02-1.18	26-30 1.02-1.18	26-30 1.02-1.18	26-30 1.02-1.18	26-30 1.02-1.18	22-25 .87-.98	22-25 .87-.98	22-25 .87-.98
E	48 1.89	48 1.89		48 1.89	48 1.89	68 2.68	68 2.68	68 2.68	68 2.68	68 2.68	68 2.68	104 4.09	104 4.09	104 4.09
M	6,7 .26	6,7 .26		6,7 .26	6,7 .26	0,5 .02	0,5 .02	0,5 .02	0,5 .02	0,5 .02	0,5 .02	2 .08	2 .08	2 .08

¹see page 56

Four Hole Panel Mounting or Mosaic Mounting

**E9
E91**

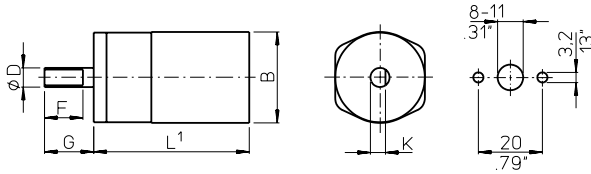

E92

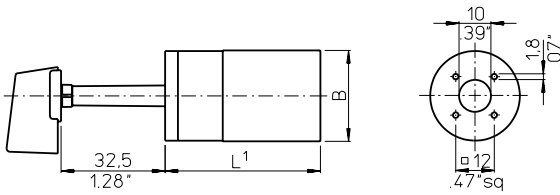

CA4
CA4
CAD4-1
29,5
1.16

B

**E93
E94**

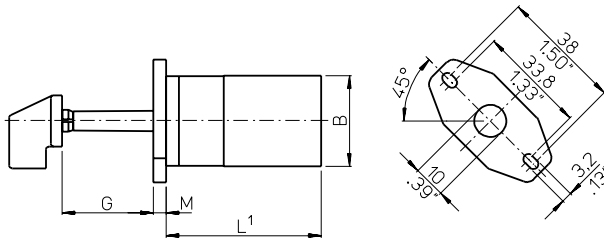

CA4
CA4-1
CAD4-1

	E9	E91	E92	E93	E94
D	6 .24	6,35 .25	-	-	-
F	12 .47	12,8 .50	-	-	-
G	15,4 .61	17,4 .69	32,5 1.28	28,5 1.12	32,5 1.28
K	4,7 .19	5,5 .22	-	-	-
M	-	-	-	4 .16	-

< back to table of contents >

**KN1
KD1
KN2**

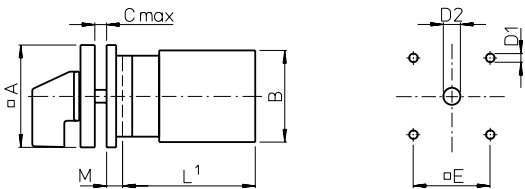

KN2	CA10 CA11 CAD11 CAD12	CA20	CA25
A	48 1.89	48 1.89	48 1.89
B	43 1.69	45 1.77	46 1.81
C	4 .16	4 .16	4 .16
D1	5 .20	5 .20	5 .20
D2	8-19 .31-.75	8-19 .31-.75	8-19 .31-.75
E	36 1.42	36 1.42	36 1.42
M	5,2 .20	5,2 .20	5,2 .20

KN1 KD1	CA10 CA11 CAD11 CAD12	CA20	CA25	CA10B CA11B CA20B	CA25B	C26	C32	C42	CA40 CA50 CA63
A	64 2.52	64 2.52	64 2.52	64 2.52	64 2.52	64 2.52	64 2.52	64 2.52	64 2.52
B	43 1.69	45 1.77	46 1.81	56 2.20	56 2.20	58 2.28	60 2.36	66 2.60	55,5x64 2.19x2.52
C	4 .16	4 .16	4 .16	4 .16	4 .16	4 .16	4 .16	4 .16	4 .16
D1	5 .20	5 .20	5 .20	5 .20	5 .20	5 .20	5 .20	5 .20	5 .20
D2	10-22 .39-.87	10-22 .39-.87	10-22 .39-.87	10-22 .39-.87	10-22 .39-.87	10-22 .39-.87	10-22 .39-.87	10-22 .39-.87	10-22 .39-.87
E	48 1.89	48 1.89	48 1.89	48 1.89	48 1.89	48 1.89	48 1.89	48 1.89	48 1.89
M	4,7 .19	4,7 .19	4,7 .19	7 .28	7 .28	7 .28	7 .28	7 .28	7 .28

¹see page 56

Two or Four Hole Panel Mounting

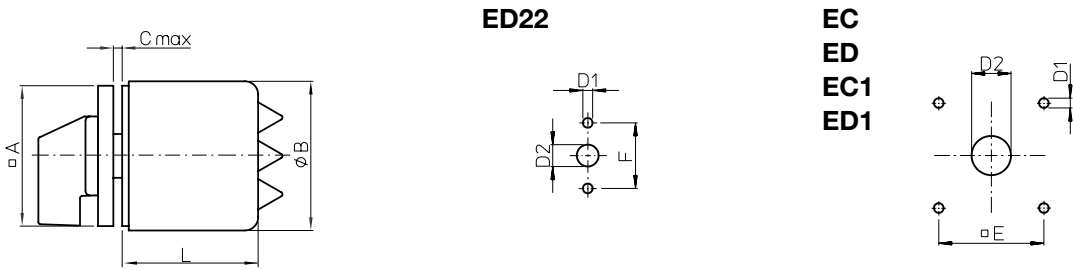

		CA10				CA20B				C26					
		CAD11		CA11		CA20		CA25		CA10B		CA11B		CA25B	
		CAD12		CA11		CA20		CA25		CA10B		CA11B		CA25B	
		EC		EC		EC		EC		EC		EC		EC	
		ED		ED22		ED		ED22		ED		ED1		ED1	
		ED		ED22		ED		ED22		ED		ED1		ED1	
A	48	48	48	48	64	48	64	48	64	64	64	64	64	64	64
	1.89	1.89	1.89	1.89	2.52	1.89	2.52	1.89	2.52	2.52	2.52	2.52	2.52	2.52	2.52
B	50	74	50	74	68	74	68	74	88	74	88	74	88	74	88
	1.97	2.91	1.97	2.91	2.68	2.91	2.68	2.91	3.46	2.91	3.46	2.91	3.46	2.91	3.46
C	4	-	4	-	4	-	4	-	4	4	4	4	4	4	4
	.16	-	.16	-	.16	-	.16	-	.16	.16	.16	.16	.16	.16	.16
D	4	4	4	4	4	4	4	4	4	4	4	4	4	4	4
	.16	.16	.16	.16	.16	.16	.16	.16	.16	.16	.16	.16	.16	.16	.16
D1	5	5	5	5	5	5	5	5	5	5	5	5	5	5	5
	.20	.20	.20	.20	.20	.20	.20	.20	.20	.20	.20	.20	.20	.20	.20
D2	8-19	-	8-19	-	10-22	-	10-22	-	10-22	10-22	10-22	10-22	10-22	10-22	10-22
	.31-.75	-	.31-.75	-	.39-.87	-	.39-.87	-	.39-.87	.39-.87	.39-.87	.39-.87	.39-.87	.39-.87	.39-.87
D2	15-19	11-15	15-19	11-15	19-22	11-15	19-22	11-15	19-22	19-22	19-22	19-22	19-22	19-22	19-22
	.43-.75	.43-.59	.43-.75	.43-.59	.75-.87	.43-.59	.75-.87	.43-.59	.75-.87	.75-.87	.75-.87	.75-.87	.75-.87	.75-.87	.75-.87
E	36	-	36	-	48	-	48	-	48	48	48	48	48	48	48
	1.42	-	1.42	-	1.89	-	1.89	-	1.89	1.89	1.89	1.89	1.89	1.89	1.89
F	-	30	-	30	-	30	-	30	-	-	-	-	-	-	-
	-	1.17	-	1.17	-	1.17	-	1.17	-	-	-	-	-	-	-
M	-	-	-	-	-	-	-	-	-	-	-	-	-	-	-
	-	-	-	-	-	-	-	-	-	-	-	-	-	-	-
Stages L	1	53,5	74,3	53,5	74,3	-	74,3	-	74,3	-	73,7	-	73,7	-	73,7
		2.10	2.93	2.10	2.93	-	2.93	-	2.93	-	2.90	-	2.90	-	2.90
2	53,5	74,3	53,5	74,3	-	74,3	-	74,3	-	73,7	-	73,7	-	73,7	
	2.10	2.93	2.10	2.93	-	2.93	-	2.93	-	2.90	-	2.90	-	2.90	
3	67,5	74,3	67,5	94,3	-	74,3	-	94,3	-	73,7	-	93,7	-	93,7	
	2.66	2.93	2.66	3.71	-	2.93	-	3.71	-	2.90	-	3.69	-	3.69	
4	67,5	74,3	81,5	94,3	-	94,3	-	94,3	-	93,7	-	93,7	-	93,7	
	2.66	2.93	3.21	3.71	-	3.71	-	3.71	-	3.69	-	3.69	-	3.69	
5	81,5	94,3	-	-	104	-	104	-	-	93,7	104	-	127	-	114,5
	3.21	3.71	-	-	4.10	-	4.10	-	-	3.69	4.10	-	5	-	4.50
6	81,5	94,3	-	-	-	-	-	-	104	-	127	-	139,5	-	127
	3.21	3.71	-	-	-	-	-	-	4.10	-	5	-	5.47	-	5
7	-	-	-	-	-	-	-	-	127	-	139,5	-	152	-	139,5
	-	-	-	-	-	-	-	-	5	-	5.47	-	5.98	-	5.47
8	-	-	-	-	-	-	-	-	127	-	152	-	164,5	-	152
	-	-	-	-	-	-	-	-	5	-	5.98	-	6.48	-	5.98
9	-	-	-	-	-	-	-	-	139,5	-	164,5	-	177	-	164,5
	-	-	-	-	-	-	-	-	5.47	-	6.48	-	6.97	-	6.48
10	-	-	-	-	-	-	-	-	152	-	177	-	-	-	177
	-	-	-	-	-	-	-	-	5.98	-	6.97	-	-	-	6.97
11	-	-	-	-	-	-	-	-	152	-	-	-	-	-	-
	-	-	-	-	-	-	-	-	5.98	-	-	-	-	-	-
12	-	-	-	-	-	-	-	-	164,5	-	-	-	-	-	-
	-	-	-	-	-	-	-	-	6.48	-	-	-	-	-	-

< back to table of contents >

Single Hole Mounting or Base Mounting

FS1...
FT1...
FT3...

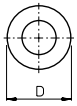

FS1...
FS2...
FS4...

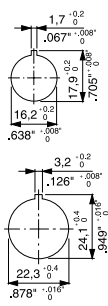

FH3...
FS2...
FT2...
FT4...



FH3...
FH4...
FT1...
FT2...
FT6...

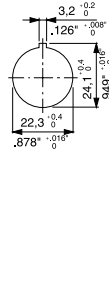

FH4...
FS4...
FT6...

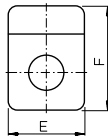

FT3...
FT4...

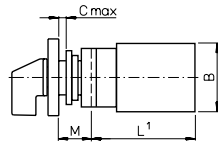
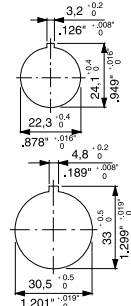

	CA4	CA10	CA11	CAD11	CA20	CA25
A/E	30	48	48	48	48	48
	1.18	1.89	1.89	1.89	1.89	1.89
FH3...	-	64	64	64	64	64
	-	2.52	2.52	2.52	2.52	2.52
FH4...	-	64	64	64	64	64
	-	2.52	2.52	2.52	2.52	2.52
B	28	43	45	46	46	46
	1.10	1.69	1.77	1.81	1.81	1.81
C	5	6	6	6	6	6
	.20	.24	.24	.24	.24	.24
D	29,5	39,4	39,4	39,4	39,4	39,4
	1.16	1.55	1.55	1.55	1.55	1.55
F	39	59	59	59	59	59
	1.54	2.32	2.32	2.32	2.32	2.32
FH4...	-	78,5	78,5	78,5	78,5	78,5
	-	3.09	3.09	3.09	3.09	3.09
M	12,5	18,2	18,2	18,2	18,2	18,2
	.49	.72	.72	.72	.72	.72
FH3...	-	25,2	25,2	25,2	25,2	25,2
	-	.99	.99	.99	.99	.99
FH4...	-	25,2	25,2	25,2	25,2	25,2
	-	.99	.99	.99	.99	.99

< back to table of contents >

VE
VE-V

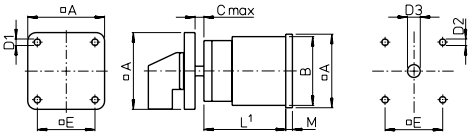

VE22
VE22V

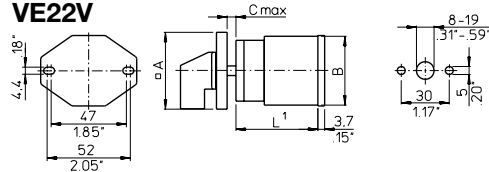

VF
VF-V

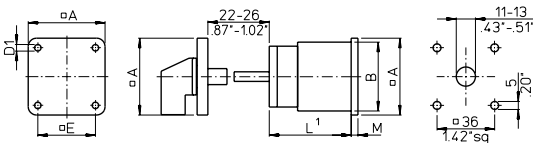

VF22
VF22V

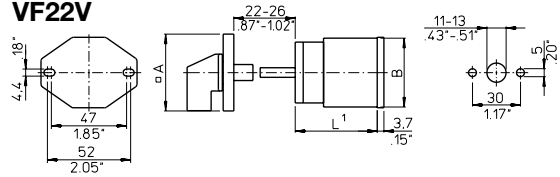

	CA10	CA11	CAD11	CA20	CA25 ²	CA10B	CA11B	CA20B	CA25B	C26	C32	C42 ²	C43	CA40 ²	CA50 ²	CA63 ²	C80	C125	C200-4	L switches	L switches
																				Size S2	Size S3
A	48	48	48	48 (64)	48 (64)	64	64	64	64	64	64	64 (88)	88	64 (88)	88	88	88	88	88	88	128
	1.89	1.89	1.89	1.89 (2.52)	1.89 (2.52)	2.52	2.52	2.52	2.52	2.52	2.52	2.52 (3.46)	3.46	2.52 (3.46)	3.46	3.46	3.46	3.46	3.46	3.46	5.04
B	43	45	46	46	46	56	56	56	56	58	60	66	84	55,5x64	84	88	88	88	88	88	126
	1.69	1.77	1.81	1.81	1.81	2.20	2.20	2.20	2.20	2.28	2.36	2.60	3.30	2.19x2.52	3.30	3.46	3.46	3.46	3.46	3.46	4.96
C	10,5	10,5	10,5	10,5	10,5	13,5	13,5	13,5	13,5	13,5	13,5	13,5	16	13,5	16	16	16	16	16	16	19,3
	.41	.41	.41	.41	.41	.53	.53	.53	.53	.53	.53	.53	.63	.53	.63	.63	.63	.63	.63	.63	.76
D1	4,1	4,1	4,1	4,1	4,1	4,1	4,1	4,1	4,1	4,1	4,1	5,4	5,4	5,4	5,4	5,4	5,4	5,4	5,4	5,4	7
	.16	.16	.16	.16	.16	.16	.16	.16	.16	.16	.16	.21	.21	.21	.21	.21	.21	.21	.21	.21	.28
D2	5	5	5	5	5	5	5	5	5	5	5	5	6	5 (6)	6	6	6	6	6	6	7
	.20	.20	.20	.20	.20	.20	.20	.20	.20	.20	.20	.20	.24	.20 (.24)	.24	.24	.24	.24	.24	.24	.28
D3	8-19	8-19	8-19	8-19	8-19	10-22	10-22	10-22	10-22	10-22	10-22	10-22	10-22	13-30	10-22	13-30	13-30	13-30	13-30	13-30	15,5-25
	.31-.75	.31-.75	.31-.75	.31-.75	.31-.75	.39-.87	.39-.87	.39-.87	.39-.87	.39-.87	.39-.87	.39-.87	.51-1.18	.39-.87	.51-1.18	.51-1.18	.51-1.18	.51-1.18	.51-1.18	.51-1.18	.61-.98
E	36	36	36 (48)	36 (48)	36 (48)	48	48	48	48	48	48	48 (68)	68	48 (68)	68	68	68	68	68	68	104
	1.42	1.42	1.42 (1.89)	1.42 (1.89)	1.42 (1.89)	1.89	1.89	1.89	1.89	1.89	1.89	1.89 (2.68)	2.68	1.89 (2.68)	2.68	2.68	2.68	2.68	2.68	2.68	4.09
M	2,2	2,2	3,2	3,2	3,2	2,5	2,5	2,5	2,5	5	5	5	7	5,1	8,9	8,9	8,9	8,9	8,9	27	11,4 (31,9)
	.09	.09	.13	.13	.13	.10	.10	.10	.10	.20	.20	.20	.28	.21	.35	.35	.35	.35	.35	1.06	.45 (1.25)

²Dimensions in () for revertive mounting plate

³Dimensions in () for L800, L1200, L1600

Base Mounting

VE1

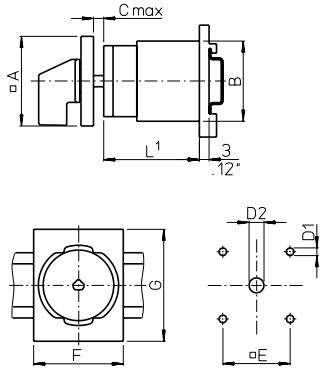

	CA10 CA11 CAD12	CA20	CA25	CA10B CA11B CA20B	CA25B	C26	C32	C42	CA40 CA50 CA63
A	48 1.89	48 1.89	48 1.89	64 2.52	64 2.52	64 2.52	64 2.52	64 2.52	64 2.52
B	43 1.69	45 1.77	46 1.81	56 2.20	56 2.20	58 2.28	60 2.36	66 2.60	55,5x64 2.19x2.52
C	10,5 .41	10,5 .41	10,5 .41	13,5 .53	13,5 .53	13,5 .53	13,5 .53	13,5 .53	13,5 .53
D1	5 .20	5 .20	5 .20	5 .20	5 .20	5 .20	5 .20	5 .20	5 .20
D2	8-15 .31-.59	8-15 .31-.59	8-15 .31-.59	10-15 .39-.59	10-15 .39-.59	10-15 .39-.59	10-15 .39-.59	10-15 .39-.59	10-15 .39-.59
E	36 1.42	36 1.42	36 1.42	48 1.89	48 1.89	48 1.89	48 1.89	48 1.89	48 1.89
F	48 1.89	48 1.89	48 1.89	70 2.76	70 2.76	70 2.76	70 2.76	70 2.76	70 2.76
G	60 2.36	60 2.36	60 2.36	60 2.36	60 2.36	60 2.36	60 2.36	60 2.36	60 2.36

VE2

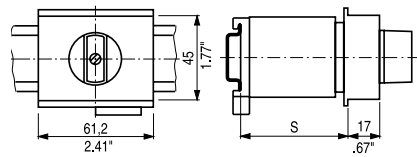

VE21 (for CA4, CA4-1 and CAD4-1)

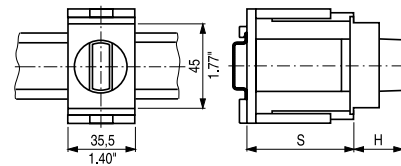

VE21 (for CA10-CA20)

VE21V (for CA25)

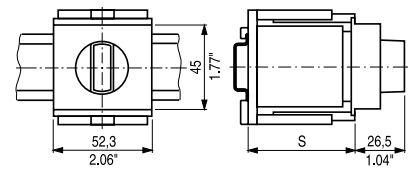

	VE2				S_{min.}	H	VE21, VE21V				
	CA10 CAD11 CAD12	CA11 CA20	CA25	Max. no. of stages			CA4 CAD4-1	CA10 CAD11 CA11	CA20	CA25	No. of stages
S = 46 1.81	3	1	-		44 1.73	21 .83	1/2	1/2	1/2	1/2	1
S = 50 1.97	-	-	1		46 1.81	26,5 1.04	3	3	-	-	2
S = 61 2.40	4	2	2		54 2.13	26,5 1.04	4	-	-	-	-
S = 67 2.64	5	-	-		56 2.20	-	-	-	3	3	-
S = 69 2.70	-	3 ²	3		60 2.36	-	-	-	-	-	3
					62 2.44	26,5 1.04	5	-	-	-	-
					66 2.60	-	-	4/5	-	-	-
					68 2.68	-	-	-	4	-	-
					70 2.76	26,5 1.04	6	-	-	4	-
					74 2.91	-	-	6	-	-	4

¹see page 56 ²not available for switch type CA20

Wall Mounting, Face plates and Additional Length

**UE1
UE2
UE3**

Lamp

	CA10	CA11	CAD11	CAD12	CA20	CA25
B	43	45	46	1.69	1.77	1.81

$L_{UE} = L^1 - 6,3$

Face plates for mounting E, EF, ER, ERF, EG, EGF, KN1, KD1, KN2, EC, EC1, ED, ED1, VE, VE1, VF

Size	A	C
S00	30 1.18	5,5 .22
S0	48 1.89	6,7 .26
S1	64 2.52	7,4 .29
S2	88 3.46	8,5 .33
S3	130 5.12	11,5 .45

Size	A	B	C
S00	30 1.18	39 1.54	5,5 .22
S0	48 1.89	59 2.32	6,7 .26
S1	64 2.52	78 3.07	7,4 .29

Additional length for amendment (page 6)

Amendment		CA10					CA40 CA50 CA63
		CAD11 CAD12	CA11 CA20 CA25	C26	C32	C42	
B	S0 switches with latching mechanism size S1	5,4 .21	-	-	-	-	-
C	S1 switches with latching mechanism size S2	-	-	9,2 .36	9,2 .36	-	8,2 .32
S	with snap action	-	17,3 .68	12,2 .48	12,2 .48	12,2 .48	12,2 .48

Quick connects for switches CA4-4

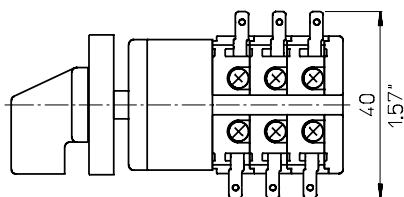

¹see page 56

Additional Length

Terminal lugs for switches C200-4-, C315, C316 and L switches

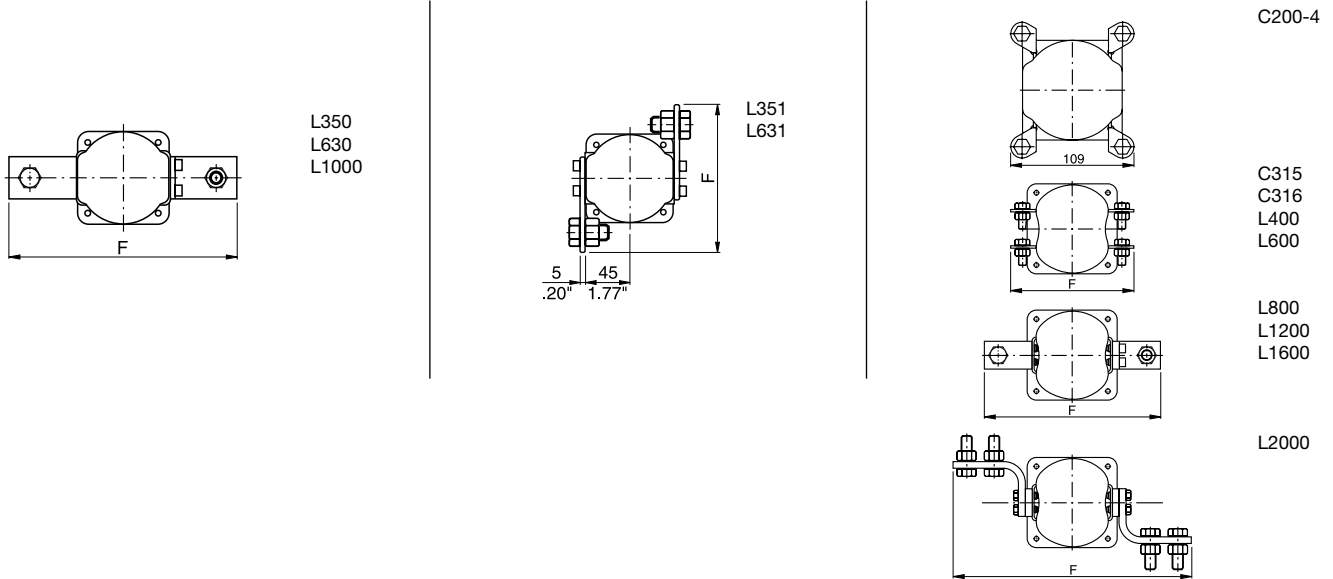

	L350	L630	L1000	L351	L631	C315 C316	L400	L600	L800 L1200	L1600 L2000
F	190 7.48	220 8.66	230 9.06	138 5.43	148 5.83	150 5.91	180 7.09	208 8.19	256 10.08	326 12.83

Length L

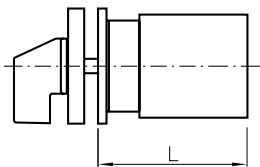

Stages	CA4 CA4-1 CAD4-1	CA10 CAD11 CAD12	CA11	CA20	CA25	CA10B	CA11B	CA20B	CA25B	C26	C32	C42	C43	CA40 CA50 CA63	C80	C125 C200-4 L switches Size S2	C315 L switches Size S3
1	30 1.18	33,5 1.32	36,7 1.44	37,7 1.48	39 1.51	38,9 1.53	42,1 1.66	43,1 1.70	44,4 1.75	42 1.65	46,8 1.84	50,8 2.00	59 2.32	42,5 1.67	61,5 2.42	67,5 2.66	78,6 3.09
2	38 1.50	43 1.69	49,4 1.94	50,4 1.98	53 2.09	48,4 1.91	54,8 2.16	55,8 2.20	58,4 2.30	54,7 2.15	64,3 2.51	72,3 2.85	80,5 3.17	55,2 2.17	88,0 3.46	100 3.94	117,2 4.61
3	46 1.81	52,5 2.07	62,1 2.44	63,1 2.48	67 2.64	57,9 2.28	67,5 2.66	68,5 2.70	72,4 2.85	67,4 2.65	81,8 3.22	93,8 3.69	102 4.02	67,9 2.67	114,5 4.51	132,5 5.22	155,8 6.13
4	54 2.13	62 2.44	74,8 2.94	75,8 2.98	81 3.19	67,4 2.65	80,2 3.16	81,2 3.20	86,4 3.40	80,1 3.15	99,3 3.91	115,3 4.54	123,5 4.86	80,6 3.17	141 5.55	165 6.50	194,4 7.65
5	62 2.44	71,5 2.81	87,5 3.44	88,5 3.48	95 3.74	76,9 3.03	92,9 3.66	93,9 3.70	100,4 3.95	92,8 3.65	116,8 4.60	136,8 5.39	145 5.71	93,3 3.67	167,5 6.59	197,5 7.78	233 9.17
6	70 2.76	81 3.19	100,2 3.94	101,2 3.98	109 4.29	86,4 3.40	105,6 4.16	106,6 4.20	114,4 4.50	105,5 4.15	134,3 5.29	158,3 6.23	166,5 6.56	106 4.17	194 7.64	230 9.06	271,6 10.69
7	78 3.07	90,5 3.56	112,9 4.44	113,9 4.48	123 4.84	95,9 3.78	118,3 4.66	119,3 4.70	128,4 5.05	118,2 4.65	151,8 5.98	179,8 7.08	188 7.40	118,7 4.67	220,5 8.68	262,5 10.33	310,2 12.21
8	86 3.39	100 3.94	125,6 4.94	126,6 4.98	137 5.39	105,4 4.15	131 5.16	132 5.20	142,4 5.60	130,9 5.15	169,3 6.67	201,3 7.93	209,5 8.25	131,4 5.17	247 9.72	295 11.61	348,8 13.73
9	94 3.70	109,5 4.31	138,3 5.44	139,3 5.48	151 5.94	114,9 4.52	143,7 5.66	144,7 5.70	156,4 6.15	143,6 5.65	186,8 7.36	222,8 8.77	231 9.09	144,1 5.67	273,5 10.77	327,5 12.89	387,4 15.25
10	-	119 4.68	151 5.94	152 5.98	165 6.50	124,4 4.90	156,4 6.16	157,4 6.20	170,4 6.70	156,3 6.15	204,3 8.04	244,3 9.62	252,2 9.54	156,8 6.17	300 11.81	360 14.17	426 16.77
11	-	128,5 5.06	163,7 6.44	164,7 6.48	179 7.05	133,9 5.27	169,1 6.66	170,1 6.70	184,4 7.25	169 6.65	221,8 8.73	265,8 10.46	274 10.79	169,5 6.67	326,5 12.85	392,5 15.45	464,6 18.29
12	-	138 5.43	176,4 6.94	177,4 6.98	193 7.60	143,4 5.65	181,8 7.16	182,8 7.20	198,4 7.80	181,7 7.15	239,3 9.42	287,3 11.31	295,5 11.63	182,2 7.17	353 13.90	425 16.73	503,2 19.81

< back to table of contents >

Notes:

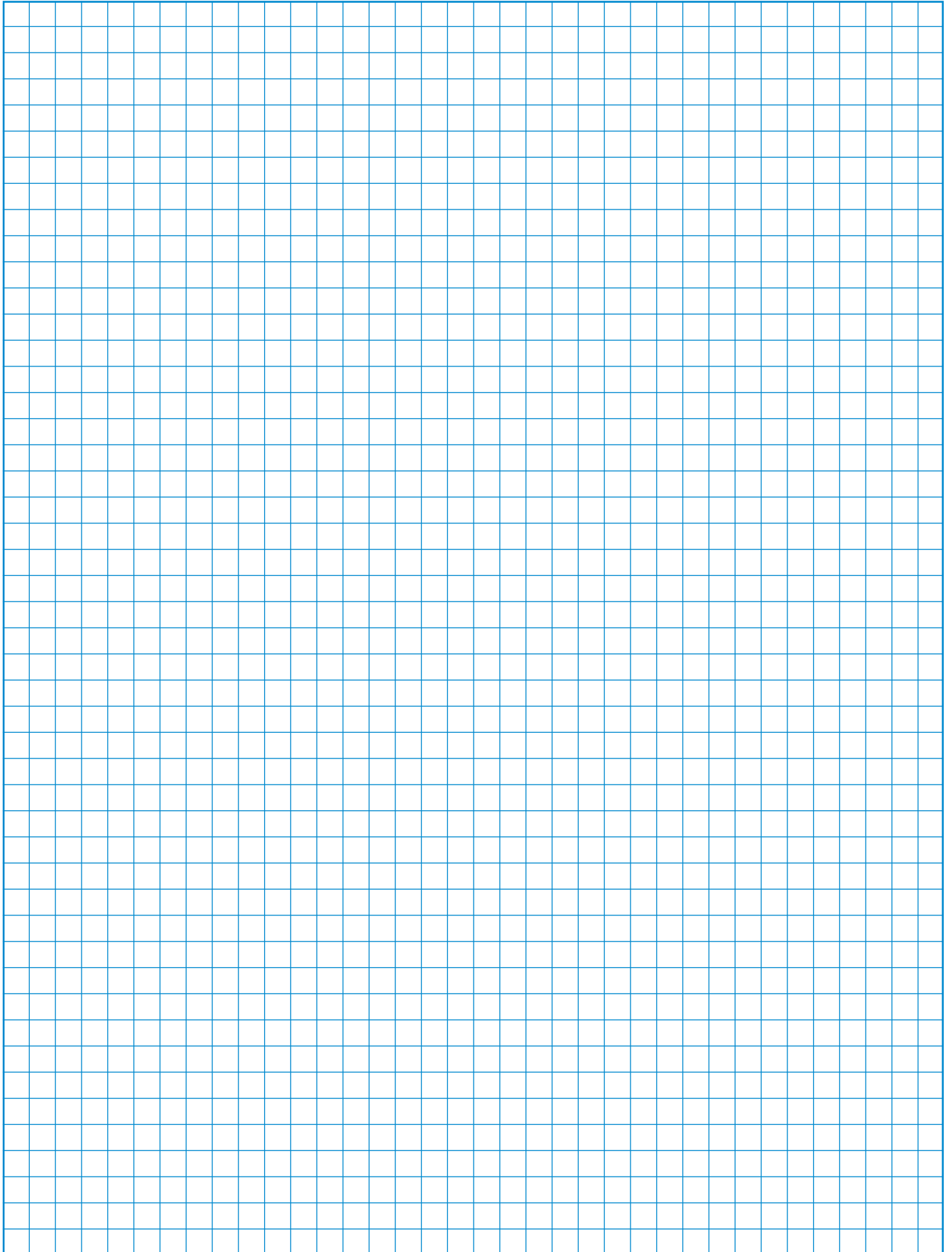

[< back to table of contents >](#)

The Range of “Blue Line” Switchgear

Technical literature covering the following products is available on request.

	Catalog Number
Main Switches and Main Switches with Emergency Function 16 A-315 A Maintenance Switches 20 A-315 A Switch Disconnectors 20 A-315 A According to IEC 60947-3, EN 60947-3, VDE 0660 part 107, IEC 60204, EN 60204 and VDE 0113	500
C, CA and CAD Switches 10 A-315 A and L Switches 350 A-2400 A C, CA and CAD switches are designed for universal application. They are recommended for instrument, isolator, double-throw and motor control. L switches are designed for load and off-load applications. They are used to switch resistive or low inductive loads.	100
Optional Extras and Enclosures The complete product line, a large number of optional extras is available, including door interlocks, push-pull devices, cylinder and padlock attachments, control and indicator devices, AC motor drives, as well as enclosures, both insulated and metal.	101
A and AD Switches 6 A-25 A A and AD switches have 4 contacts in each switching stage. These switches provide an extensive range of switch functions and require a minimum mounting depth. Up to 24 switching positions are possible, with availability of 48 contacts per 12 stage switch column.	110
CG, CH and CHR Switches 10 A-25 A Ultra compact CG, CH and CHR switches are ideally suited for control and instrumentation applications. Switch terminals are “finger-proof” and conveniently accessible for wiring and are delivered open. All CG4 switches offer specially designed gold plated contacts or H-bridges with “cross-wire” contact systems, which facilitates their use in electronic circuitry and chemically aggressive environments.	120
DH, DHR, DK and DKR Switches 6 A-16 A DH, DHR, DK and DKR switches incorporate unique corrosion resistant contacts that permit operation on system voltage as low as 1 V. They have fully enclosed and protected contacts which can be operated either by rotary and/or lateral handle movement. D switches are used in calibration and semiconductor circuits. They are also used for relay and contactor control.	130
X Switches 200 A-630 A X switches can be applied for load, tap and gang switching duties. They incorporate 6 contacts in each switching stage. Their compact design provides a minimum length dimension for mounting purposes.	140
KG Switches 20 A-315 A and KH and KHR Switches 16 A-80 A KG, KH and KHR switches are excellent circuit interruptors. They have high through fault and fault making capacities and are especially designed for use as isolators and safety switches for machine tools, distribution panels and switchboards. KG ON/OFF switches offer unusually high dimensioned air and creepage distances between terminals which are designed for time saving “straight-line” wiring. ON/OFF switches are available with up to 8 poles and double-throw switches are available with up to 4 poles.	150
Push Buttons and Pilot Lights, 22,5 mm Ø A complete range of state-of-the-art push buttons and pilot lights represent an ideal combination of functional security and economical efficiency in a modular design.	302